

**SCHENECTADY COUNTY**  
NEW YORK



**ADOPTED**  
**2025-2030**  
**CAPITAL IMPROVEMENT**  
**PROGRAM**

## TABLE OF CONTENTS

<b><u>CAPITAL PROGRAM SUMMARY CHARTS</u></b>	<b><u>PAGE NO.</u></b>
1. ADOPTED CAPITAL PROJECTS FOR 2025	1
2. ADOPTED CAPITAL EQUIPMENT FOR 2025	2
3. ADOPTED CAPITAL BUDGET DETAIL 2025 - 2030	3
4. ADOPTED VEHICLE PURCHASE LIST 2025	6
<b><u>CAPITAL PROJECT REQUESTS, DETAILED INFORMATION</u></b>	<b>8</b>
1. AVIATION	9
2. CIVIL SERVICE/HUMAN RESOURCES	11
3. ENGINEERING AND PUBLIC WORKS	12
4. FACILITIES	14
5. GLENDALE NURSING HOME	34
6. INFORMATION SERVICES	35
7. SCHENECTADY COUNTY COMMUNITY COLLEGE	36
<b><u>CAPITAL EQUIPMENT REQUESTS, DETAILED INFORMATION</u></b>	<b>40</b>
1. BOARD OF ELECTIONS	41
2. ENGINEERING AND PUBLIC WORKS	42
3. GLENDALE NURSING HOME	54
4. INFORMATION SERVICES	56
5. PURCHASING	58
6. SHERIFF	59
<b><u>FUTURE CAPITAL PLAN REQUESTS 2026-2030</u></b>	<b>61</b>

**2025**  
**ADOPTED CAPITAL PROJECTS & EQUIPMENT**

Dept./Page No.	Project Number	COUNTY APPROPRIATIONS		REIMBURSEMENTS		TOTAL
		OPERATING	SERIAL BONDS	STATE	FEDERAL	
<b>TOTAL CAPITAL REQUESTS-YEAR 2025: PROJECTS</b>		<b>\$ 1,010,000</b>	<b>\$ 10,290,650</b>	<b>\$ 5,076,000</b>	<b>\$ 6,092,350</b>	<b>\$ 22,469,000</b>
<b><u>Aviation</u></b>						
9	General Aviation North Apron Reconstruction (Construction/Inspection)	H5610250001	\$ 320,650		\$ 6,092,350	\$ 6,413,000
10	Storage Building for Airport Equipment	H1620250002	\$ 1,100,000			\$ 1,100,000
<b><u>Civil Service/Human Resources</u></b>						
11	Human Resources Software-Onboarding & Application	H1430250003	\$ 100,000			\$ 100,000
<b><u>Engineering and Public Works</u></b>						
12	County Highway Improvements/County-Wide Highway System	H5110250004	\$ 2,000,000	\$ 3,376,000		\$ 5,376,000
13	DEPW: Rehabilitation of Recycling Building	H5110250005	\$ 500,000			\$ 500,000
<b><u>Facilities</u></b>						
14	797 Broadway: Building Upgrades Phase 2	H1620250006	\$ 1,635,000			\$ 1,635,000
15	797 Broadway: HVAC Controls Change Out	H1620250007	\$ 300,000			\$ 300,000
16	Aviation: Roof Replacement Project at the Airport Tower	H1620250008	\$ 250,000			\$ 250,000
17	Business Center: Fire Alarm Replacement	H1620250009	\$ 100,000			\$ 100,000
18	Courthouse & COB Fire System Separation Design Year	H1620250010	\$ 70,000			\$ 70,000
19	Courthouse Basement Area & Mechanical Room Phase 3	H1620250011	\$ 300,000			\$ 300,000
20	Courthouse: Boiler Room Project	H1620250012	\$ 300,000			\$ 300,000
21	Jail: Build Shed w/ Lighting for Storage in Blue Lot	H1620250014	\$ 15,000			\$ 15,000
22	Jail: Cell Night Lights	H1620250015	\$ 300,000			\$ 300,000
23	Jail: Dorm Windows Replacement	H1620250016	\$ 500,000			\$ 500,000
24	Jail: Drains and Penthouse	H1620250017	\$ 50,000			\$ 50,000
25	Jail: Fires Sprinkler Head Change Out	H1620250018	\$ 75,000			\$ 75,000
26	Jail: Flush Valves Phase 2	H1620250019	\$ 500,000			\$ 500,000
27	Jail: Repair Brick w/ Stainless Steel Guard Exterior Visitor Area	H1620250020	\$ 30,000			\$ 30,000
28	Jail: Sally Port W1 Gate Demolition & Replacement	H1620250021	\$ 125,000			\$ 125,000
29	Library: Bookdrops Project	H1620250022	\$ 50,000			\$ 50,000
30	Library: Fire Panels Phase 2	H1620250023	\$ 200,000			\$ 200,000
31	Library: Signage Project Phase 1	H1620250024	\$ 60,000			\$ 60,000
32	Library: Woodlawn Library Feasibility Study for Quaker & Woodlawn Expansion	H1620250025	\$ 75,000			\$ 75,000
33	Unified Communication Center: HVAC upgrade Phase 1	H1620250026	\$ 75,000			\$ 75,000
<b><u>Glendale Nursing Home</u></b>						
34	Glendale: Garage	B1620250027	\$ 500,000			\$ 500,000
<b><u>Information Services</u></b>						
35	IT Security Tools	H1621250028	\$ 70,000			\$ 70,000
<b><u>Schenectady County Community College</u></b>						
36	Begley Basement Renovation	H2401250029	\$ 750,000	\$ 750,000		\$ 1,500,000
37	Culinary Program Kitchen Ventilation & Dining Room Renovation	H2401250030	\$ 300,000	\$ 300,000		\$ 600,000
38	Elston Hall: Gathering Area and Kitchen Renovation	H2401250031	\$ 625,000	\$ 625,000		\$ 1,250,000
39	Mechanical, Electrical, and Plumbing Study	H2401250032	\$ 25,000	\$ 25,000		\$ 50,000

**2025**  
**ADOPTED CAPITAL PROJECTS & EQUIPMENT**

Dept./Page No.	Project Number	COUNTY APPROPRIATIONS		REIMBURSEMENTS		TOTAL	
		OPERATING	SERIAL BONDS	STATE	FEDERAL		
<b>TOTAL CAPITAL REQUESTS-YEAR 2025: EQUIPMENT</b>		<b>\$ 1,273,750</b>	<b>\$ 2,515,000</b>			<b>\$ 3,788,750</b>	
<b><u>Board of Elections</u></b>							
41	New Voting Machines	H1450250033		\$ 1,000,000		\$ 1,000,000	
<b><u>Engineering and Public Works</u></b>							
42	DEPW: Refurbish Equipment	H5130250034	\$ 100,000			\$ 100,000	
43	Equipment Replacement: New TCX 635 PHD Large Truck Tire Changer	H5130250035	\$ 47,000			\$ 47,000	
44	Equipment: New 2025 Guardrail Post Pounder, GRT Utilicorp	H5130250036		\$ 255,000		\$ 255,000	
45	Equipment: Two (2) New Trailers: Facilites & DEPW	H5130250037	\$ 26,000			\$ 26,000	
46	Fleet Replacement: General County Inventory	H5130250038	\$ 395,000			\$ 395,000	
47	Fleet Replacement: MV 607 SBA 4x2 Crew Truck with Dump Body	H5130250039		\$ 145,000		\$ 145,000	
48	Fleet Replacement: New 2025 DD25B Volvo Asphalt Roller	H5130250040	\$ 52,000			\$ 52,000	
49	Fleet Replacement: New 2025 HV507 SFA Single Axle Dump Truck	H5130250041		\$ 275,000		\$ 275,000	
50	Fleet Replacement: New 2025 HX520 SFA Tandem Dump Truck	H5130250042		\$ 330,000		\$ 330,000	
51	Fleet Replacement: New 2025 International Dump Truck 6x6	H5130250043		\$ 300,000		\$ 300,000	
52	Fleet Replacement: New 2025 T66 T4 Bobcat Compact Track Loader	H5130250044		\$ 78,000		\$ 78,000	
53	Fleet Replacement: New 2025 Volvo ECR88D Excavator	H5130250045		\$ 132,000		\$ 132,000	
<b><u>Glendale Nursing Home</u></b>							
54	Fleet Replacement: Glendale 2025 2500 Chevy or Ford F-250	B6031250046	\$ 59,000			\$ 59,000	
55	Nurse Call Bell System for 1 Unit	B6031250047	\$ 50,750			\$ 50,750	
<b><u>Information Services</u></b>							
56	Network Switch Upgrade	H1621250048	\$ 100,000			\$ 100,000	
57	Network Test Equipment	H1621250049	\$ 45,000			\$ 45,000	
<b><u>Purchasing</u></b>							
58	Copiers and Equipment	H1345250050	\$ 30,000			\$ 30,000	
<b><u>Sheriff - All Divisions</u></b>							
59	Sheriff Dept.: 2025 Ford Explorer for Task Force Unit	H3160250051	\$ 65,000			\$ 65,000	
60	Sheriff Dept.: Vehicle Replacements and Upfitting	H3110250052	\$ 304,000			\$ 304,000	
<b>TOTAL CAPITAL -YEAR 2025: PROJECTS &amp; EQUIPMENT</b>			<b>\$ 2,283,750</b>	<b>\$ 12,805,650</b>	<b>\$ 5,076,000</b>	<b>\$ 6,092,350</b>	<b>\$ 26,257,750</b>

**5 YEAR ADOPTED CAPITAL BUDGET  
2025-2030**

	2025	2026	2027	2028	2029	2030	Grand Total
<b>Aviation</b>	<b>\$ 7,513,000.00</b>	<b>\$ 70,000.00</b>					<b>\$ 7,583,000.00</b>
General Aviation North Apron Reconstruction (Construction/Inspection)	\$ 6,413,000.00						\$ 6,413,000.00
Mini-Split Replacement for Tower Cab		\$ 70,000.00					\$ 70,000.00
Storage Building for Airport Equipment	\$ 1,100,000.00						\$ 1,100,000.00
<b>Board of Elections</b>	<b>\$ 1,000,000.00</b>						<b>\$ 1,000,000.00</b>
New Voting Machines	\$ 1,000,000.00						\$ 1,000,000.00
<b>Civil Service/Human Resources</b>	<b>\$ 100,000.00</b>						<b>\$ 100,000.00</b>
Human Resources Software-Onboarding & Application	\$ 100,000.00						\$ 100,000.00
<b>Engineering and Public Works</b>	<b>\$ 8,011,000.00</b>				<b>\$ 1,500,000.00</b>		<b>\$ 9,511,000.00</b>
Emergency Management Office: 2025 Mobile Command Post Vehicle					\$ 1,500,000.00		\$ 1,500,000.00
County Highway Improvements/County-Wide Highway System	\$ 5,376,000.00						\$ 5,376,000.00
DEPW: Refurbish Equipment	\$ 100,000.00						\$ 100,000.00
DEPW: Rehabilitation of Recycling Building	\$ 500,000.00						\$ 500,000.00
Equipment Replacement: New TCX 635 PHD Large Truck Tire Changer	\$ 47,000.00						\$ 47,000.00
Equipment: New 2025 Guardrail Post Pounder, GRT Utilicorp	\$ 255,000.00						\$ 255,000.00
Equipment: Two (2) New Trailers: Facilites & DEPW	\$ 26,000.00						\$ 26,000.00
Fleet Replacement: General County Inventory	\$ 395,000.00						\$ 395,000.00
Fleet Replacement: MV 607 SBA 4x2 Crew Truck with Dump Body	\$ 145,000.00						\$ 145,000.00
Fleet Replacement: New 2025 DD25B Volvo Asphalt Roller	\$ 52,000.00						\$ 52,000.00
Fleet Replacement: New 2025 HV507 SFA Single Axle Dump Truck	\$ 275,000.00						\$ 275,000.00
Fleet Replacement: New 2025 HX520 SFA Tandem Dump Truck	\$ 330,000.00						\$ 330,000.00
Fleet Replacement: New 2025 International Dump Truck 6x6	\$ 300,000.00						\$ 300,000.00
Fleet Replacement: New 2025 T66 T4 Bobcat Compact Track Loader	\$ 78,000.00						\$ 78,000.00
Fleet Replacement: New 2025 Volvo ECR88D Excavator	\$ 132,000.00						\$ 132,000.00
<b>Facilities</b>	<b>\$ 5,010,000.00</b>	<b>\$ 11,630,000.00</b>		<b>\$ 100,000.00</b>			<b>\$ 16,740,000.00</b>
797 Broadway: Building Upgrades Phase 2	\$ 1,635,000.00						\$ 1,635,000.00
797 Broadway: HVAC Controls Change Out	\$ 300,000.00						\$ 300,000.00
Aviation: Roof Replacement Project at the Airport Tower	\$ 250,000.00						\$ 250,000.00
Business Center: Exterior Rehabilitation		\$ 150,000.00					\$ 150,000.00
Business Center: Fire Alarm Replacement	\$ 100,000.00						\$ 100,000.00
Business Center: Interior Upgrades		\$ 30,000.00					\$ 30,000.00
County Office Building: Streetscape Phase 2 (Courthouse & 608 State)		\$ 750,000.00					\$ 750,000.00
Courthouse & COB Fire System Separation Design Year	\$ 70,000.00						\$ 70,000.00
Courthouse Basement Area & Mechanical Room Phase 3	\$ 300,000.00						\$ 300,000.00
Courthouse Exterior Masonry		\$ 1,000,000.00					\$ 1,000,000.00
Courthouse Facade Renovation		\$ 1,000,000.00					\$ 1,000,000.00
Courthouse Lobby refresh PH1 & Reimagine Historic		\$ 1,500,000.00					\$ 1,500,000.00
Courthouse: Bathroom Renovation Phase 2		\$ 500,000.00					\$ 500,000.00
Courthouse: Boiler Room Project	\$ 300,000.00						\$ 300,000.00
Courthouse: Electrical Panel Upgrades		\$ 750,000.00					\$ 750,000.00
Courthouse: Exterior Rehabilitation		\$ 750,000.00					\$ 750,000.00
DEPW: Roof Replacement Barrel Vault Roof		\$ 1,500,000.00					\$ 1,500,000.00
Jail: Booking Area Refresh		\$ 400,000.00					\$ 400,000.00
Jail: Build Shed w/ Lighting for Storage in Blue Lot	\$ 15,000.00						\$ 15,000.00
Jail: Cell Night Lights	\$ 300,000.00						\$ 300,000.00
Jail: Dorm Hallway Refresh		\$ 150,000.00					\$ 150,000.00
Jail: Dorm Windows Replacement	\$ 500,000.00						\$ 500,000.00
Jail: Drains and Penthouse	\$ 50,000.00						\$ 50,000.00

**5 YEAR ADOPTED CAPITAL BUDGET  
2025-2030**

	2025	2026	2027	2028	2029	2030	Grand Total
Jail: Epoxy Floors 1-4 Phase 3		\$ 500,000.00					\$ 500,000.00
Jail: Exterior Phase 3		\$ 175,000.00					\$ 175,000.00
Jail: Fires Sprinkler Head Change Out	\$ 75,000.00						\$ 75,000.00
Jail: Flush Valves Phase 2	\$ 500,000.00						\$ 500,000.00
Jail: In Depth Design Study of the Jail		\$ 65,000.00					\$ 65,000.00
Jail: Locker Room and Administrative Area Refresh		\$ 750,000.00					\$ 750,000.00
Jail: Locker Room Phase 2 and Administration Area		\$ 750,000.00					\$ 750,000.00
Jail: Parking Lot Lights		\$ 150,000.00					\$ 150,000.00
Jail: Repair Brick w/ Stainless Steel Guard Exterior Visitor Area	\$ 30,000.00						\$ 30,000.00
Jail: Roof Replacement		\$ 55,000.00					\$ 55,000.00
Jail: Sally Port W1 Gate Demolition & Replacement	\$ 125,000.00						\$ 125,000.00
Library: Bookdrops Project	\$ 50,000.00						\$ 50,000.00
Library: Branch Library Parking Lot Sealant		\$ 75,000.00					\$ 75,000.00
Library: Exterior Project Phase 1		\$ 150,000.00					\$ 150,000.00
Library: Fire Panels Phase 2	\$ 200,000.00						\$ 200,000.00
Library: Interior Project Various Branches Phase 1		\$ 300,000.00					\$ 300,000.00
Library: KBJ Library 2nd Floor Design Year		\$ 50,000.00					\$ 50,000.00
Library: KBJ Library Multistack Chiller Controls				\$ 100,000.00			\$ 100,000.00
Library: Niskayuna Branch Parking Lights & Sidewalks Phase 2		\$ 130,000.00					\$ 130,000.00
Library: Signage Project Phase 1	\$ 60,000.00						\$ 60,000.00
Library: Woodlawn Library Feasibility Study for Quaker & Woodlawn Expansion	\$ 75,000.00						\$ 75,000.00
Unified Communication Center: HVAC upgrade Phase 1	\$ 75,000.00						\$ 75,000.00
<b>Glendale Nursing Home</b>	<b>\$ 609,750.00</b>	<b>\$ 50,750.00</b>	<b>\$ 50,750.00</b>	<b>\$ 50,750.00</b>			<b>\$ 762,000.00</b>
Fleet Replacement: Glendale 2025 2500 Chevy or Ford F-250	\$ 59,000.00						\$ 59,000.00
Glendale: Garage	\$ 500,000.00						\$ 500,000.00
Nurse Call Bell System for 1 Unit	\$ 50,750.00						\$ 50,750.00
Nurse Call Bell System Phase 3		\$ 50,750.00					\$ 50,750.00
Nurse Call Bell System Phase 4			\$ 50,750.00				\$ 50,750.00
Nurse Call Bell System Phase 5				\$ 50,750.00			\$ 50,750.00
<b>Information Services</b>	<b>\$ 215,000.00</b>						<b>\$ 215,000.00</b>
IT Security Tools	\$ 70,000.00						\$ 70,000.00
Network Switch Upgrade	\$ 100,000.00						\$ 100,000.00
Network Test Equipment	\$ 45,000.00						\$ 45,000.00
<b>Purchasing</b>	<b>\$ 30,000.00</b>						<b>\$ 30,000.00</b>
Copiers and Equipment	\$ 30,000.00						\$ 30,000.00
<b>Schenectady County Community College</b>	<b>\$ 3,400,000.00</b>	<b>\$ 16,650,000.00</b>	<b>\$ 1,000,000.00</b>				<b>\$ 21,050,000.00</b>
Begley Basement Renovation	\$ 1,500,000.00						\$ 1,500,000.00
Classroom Furniture Replacement		\$ 750,000.00					\$ 750,000.00
College-wide Fire Alarm		\$ 1,500,000.00					\$ 1,500,000.00
Culinary Program Kitchen Ventilation & Dining Room Renovation	\$ 600,000.00						\$ 600,000.00
Data Center Consolidation		\$ 2,500,000.00					\$ 2,500,000.00
Daycare Center Playground & Quad Beautification		\$ 800,000.00					\$ 800,000.00
Elston Hall: Basement Hallway Renovation		\$ 1,000,000.00					\$ 1,000,000.00
Elston Hall: Facade & Window Restoration		\$ 2,500,000.00					\$ 2,500,000.00
Elston Hall: Facade Phase 5			\$ 1,000,000.00				\$ 1,000,000.00
Elston Hall: Gathering Area and Kitchen Renovation	\$ 1,250,000.00						\$ 1,250,000.00
Elston Hall: Student Affairs Renovation		\$ 4,500,000.00					\$ 4,500,000.00
Elston Hall: Testing Center Expansion & Renovation		\$ 1,600,000.00					\$ 1,600,000.00
Mechanical, Electrical, and Plumbing Study	\$ 50,000.00						\$ 50,000.00

**5 YEAR ADOPTED CAPITAL BUDGET  
2025-2030**

	2025	2026	2027	2028	2029	2030	Grand Total
Van Curler Room Restoration		\$ 1,500,000.00					\$ 1,500,000.00
<b><u>Schenectady County Compost &amp; Recycling Facility</u></b>			\$ 343,000.00				\$ 343,000.00
Compost Facility Front End Loader			\$ 343,000.00				\$ 343,000.00
<b><u>Sheriff - All Divisions</u></b>	\$ 369,000.00	\$ 250,000.00	\$ 250,000.00	\$ 250,000.00	\$ 250,000.00	\$ 250,000.00	\$ 1,619,000.00
Sheriff Dept.: 2025 Ford Explorer for Task Force Unit	\$ 65,000.00						\$ 65,000.00
Sheriff Dept.: Vehicle Replacements and Upfitting	\$ 304,000.00	\$ 250,000.00	\$ 250,000.00	\$ 250,000.00	\$ 250,000.00	\$ 250,000.00	\$ 1,554,000.00
<b><u>Unified Communication Center</u></b>		\$ 1,700,000.00					\$ 1,700,000.00
Countywide CAD/RMS		\$ 1,700,000.00					\$ 1,700,000.00
<b>TOTAL CAPITAL PROJECT REQUESTS- YEAR 2025-2030</b>	\$ 26,257,750.00	\$ 30,350,750.00	\$ 1,643,750.00	\$ 400,750.00	\$ 1,750,000.00	\$ 250,000.00	\$ 60,653,000.00

**VEHICLE FLEET REPLACEMENT  
2025 CAPITAL BUDGET**

<b>New Vehicle Requested</b>			<b>Vehicle to be Replaced</b>			
<b>VEHICLE REPLACEMENTS:</b>						
<u>Vehicle Type</u>	<u>Dept</u>	<u>Cost</u>	<u>Vehicle #</u>	<u>Year</u>	<u>Description</u>	<u>Justification</u>
New Chevy Colorado regular cab with toolbox and standard features	DEPW	\$49,000	1022	2010	Chevy Colorado	1002 will have approximately 88,000 miles at time of replacement. It is very rusted will go to auction frame has rust holes
New Chevy 2500 pickup extended cab with 8 foot box with standard features	DEPW	\$57,000	1011	2018	Chevy Pickup	This unit will replace 1011 a 2018 Chevy pickup for the parts department which will have approximately 150,000 miles at the time of replacement. 1011 will replace 1324 which has 183,000 miles and will go to auction
2025 Rack truck 5500 with tool box and running boards	DEPW	\$95,000	1104	2014	Rack Truck	This unit will replace 1104 which is 10 years old with 90,000 miles at the time of replacement
New 2025 Chevy Malibu with standard features	DA	\$28,000	3109	2014	Ford Fusion	This unit will replace 3109 a 2014 Ford Fusion, 3109 will replace 1014 a 2012 Ford Fusion which will have approximately 120,000 miles at the time of replacement and will go to auction
New 2025 Chevy Malibu with standard features	DA	\$28,000	3108	2014	Ford Fusion	This unit will replace 3108 a 2014 Ford Fusion, 3108 will replace 1013 a 2012 Ford Fusion which will have approximately 115,000 miles at the time of replacement and will go to auction
New Chevy Malibu with standard features	DSS	\$28,000	2179	2014	Ford Fusion	This unit will replace 2179 a 2014 Ford Fusion with approximately 108,000 miles at the time of replacement, this vehicle is 11 years old and will go to auction
New 2025 Ford Explorer With standard equipment and emergency lights	Emergency Management	\$55,000	3322	2013	Ford Fusion	This unit will replace 3322 a 2013 Ford Explorer which will have approximately 128,000 miles at the time of replacement and will go to auction
2025 Chrysler Pacifica Hybrid with standard features	Purchasing	\$55,000	4101	2014	Chevy Express	This unit will replace 4101, a 10 year old 15 passenger Chevy Express van previously used by the Sheriff's Dept. to transport prisoners. It will have approx. 127,000 miles on it at the time of replacement and starting to rust. The vehicle is not good in the snow or ice, and is too big for most of his assigned tasks. 4101 will go to auction.
<b>GRAND TOTAL 2025 VEHICLE REPLACEMENTS :</b>		<b>\$395,000</b>				



**VEHICLE FLEET REPLACEMENT  
2025 CAPITAL BUDGET**

**TASK FORCE**

<u>New Vehicle Requested</u>			<u>Vehicle to be Replaced</u>			
<u>VEHICLE REPLACEMENTS:</u>	<u>(Listed Separately on Capital Budget)</u>					
<u>Vehicle Type</u>	<u>Dept</u>	<u>Cost</u>	<u>Vehicle #</u>	<u>Year</u>	<u>Description</u>	<u>Justification</u>
2025 Ford Explorer with standard features with emergency lights	Task Force	\$65,000				New vehicle request
<b>GRAND TOTAL 2025 VEHICLE REPLACEMENTS :</b>		<b>\$65,000</b>				

**SHERIFF**

<u>New Vehicle Requested</u>			<u>Vehicle to be Replaced</u>			
<u>VEHICLE REPLACEMENTS:</u>	<u>(Listed Separately on Capital Budget)</u>					
<u>Vehicle Type</u>	<u>Dept</u>	<u>Cost</u>	<u>Vehicle #</u>	<u>Year</u>	<u>Description</u>	<u>Justification</u>
Ford Interceptors (3) with Upfitting	Sheriff	\$249,000	various		Ford Interceptors	\$83,000 each. These may replace 2389 and 2360
Chevy 3500 Express Van with standard options and police features for the Jail	Sheriff	\$55,000	2378	2017	Chevy Express Van	This unit will replace 2378, which will have approx. 150,000 miles at time of replacement. 2378 will replace 3612, a 2005 Chevy Express Van that will go to auction.
<b>GRAND TOTAL 2025 VEHICLE REPLACEMENTS :</b>		<b>\$304,000</b>				

# **CAPITAL PROJECT REQUESTS 2025**



# Schenectady County 2025 Capital Budget Request

**Request Year:** 2025

**Department:** Aviation

**Project Name:** General Aviation North Apron Reconstruction (Construction/Inspection)

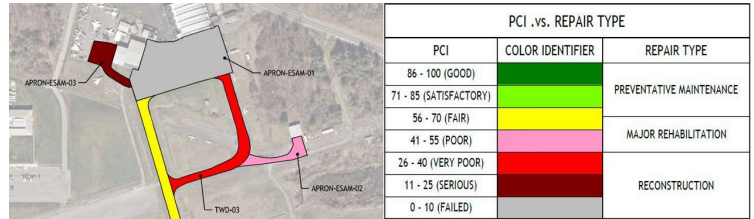

**Classification:** Project

**Type:** New

**Estimated Start:** 8/1/2025

**Estimated Completion:** 4/1/2026

**Estimated Cost:** \$6,413,000

Federal Funding	State Funding	County Funding
\$6,092,350	\$0	\$320,650

**Project Description:**

This project includes the construction and construction administration/inspection for the reconstruction of the General Aviation (GA) North Apron and adjacent jug-handle taxi lane. Reconstruction of the existing apron's asphalt (550ft x 250ft) and jug-handle taxi lane (850ft x 45ft) includes full-depth removal of the existing pavement section (asphalt and subbase stone), replacement of new structural subbase, crushed aggregate base course and bituminous asphalt paving. This project also includes the repair/maintenance of existing drainage, installation of a new storm water retention structure for climate resiliency and reconstruction of apron lighting, security gate access and placement of Federal Aviation Administration(FAA) required pavement markings.

**Justification:**

The associated apron and taxi lane have exceeded their 20-year design life while also degrading to an average Pavement Condition Index (PCI) of approximately 17-20 (serious). A PCI is a rating from 0 (failed) to 100 (new), the current condition of the asphalt risks damage to any aircraft that travels over it under their own power. This is the final section of the airports existing asphalt that hasn't been upgraded within the last 20 years. Once this is completed, the average PCI rating of the airport will be 85+ (good-new). With a reconstruction project, New York State Department of Transportation and the FAA require a percentage of the asphalt be treated as new for storm water purposes. This is to reduce down stream runoff and flooding potential caused by increased rain events.



# Schenectady County 2025 Capital Budget Request

**Request Year:** 2025

**Department:** Aviation

**Project Name:** Storage Building for Airport Equipment

**Classification:** Project

**Type:** New



**Estimated Start:** 4/1/2025                      **Estimated Completion:** 10/1/2025

**Estimated Cost:** \$1,100,000

Federal Funding	State Funding	County Funding
\$0	\$0	\$1,100,000

**Project Description:**

Construction of a new airport maintenance storage building to house maintenance equipment during the winter months. The building will be approximately 100 feet long by 25 feet deep.

**Justification:**

The airport mowers are currently stored in an old storage building between Taxiway "E" and the properties along Habel Lane. The County is in the process of amending our lease with the Air National Guard to expand their current leased area. The area where the existing storage building is located will become part of the Air National Guard lease and the buildings will be removed. A new storage building will be needed to house all current and future equipment when not in use.



# Schenectady County 2025 Capital Budget Request

**Request Year:** 2025  
**Department:** Civil Service/Human Resources  
**Project Name:** Human Resources Software-Onboarding & Application  
**Classification:** Project  
**Type:** New

The screenshot shows the NEOGOV interface for a requisition. A donut chart displays the candidate status: 16 Total, with 2 Hired, 1 Offered, 2 Second Interview, 3 Interview, 7 Referred, and 1 Rejected. Below the chart is a table of candidates with columns for Name, Master Profile, Total Rank, Notices, Status, and Rating. The table lists candidates such as Sharon Henry, Danna Gomez, Kelly Crawford, and Nicole Price.

**Estimated Start:** 1/1/2025                                  **Estimated Completion:** 12/31/2025  
**Estimated Cost:** \$100,000

Federal Funding	State Funding	County Funding
\$0	\$0	\$100,000

**Project Description:**  
 Implement new software to allow for electronic onboarding and application tracking.

**Justification:**  
 Implementation of the software would allow us to onboard individuals more accurately and efficiently.



# Schenectady County 2025 Capital Budget Request

**Request Year:** 2025

**Department:** Engineering and Public Works

**Project Name:** County Highway Improvements/County-Wide Highway System

**Classification:** Project

**Type:** Replacement/Renewal



**Estimated Start:** 4/1/2025                      **Estimated Completion:** 10/31/2025

**Estimated Cost:** \$5,376,000

Federal Funding	State Funding	County Funding
\$0	\$3,376,000	\$2,000,000

**Project Description:**

2025 repaving and reconstruction of the County's highways.

**Justification:**

Articles 5 & 6 of the New York State Highway Law.



# Schenectady County 2025 Capital Budget Request

**Request Year:** 2025

**Department:** Engineering and Public Works

**Project Name:** DEPW: Rehabilitation of Recycling Building

**Classification:** Project

**Type:** Replacement/Renewal



**Estimated Start:** 1/1/2025                      **Estimated Completion:** 12/31/2025

**Estimated Cost:** \$500,000

Federal Funding	State Funding	County Funding
\$0	\$0	\$500,000

**Project Description:**

Rehabilitation of Recycling Building at DEPW

**Justification:**

Rehabilitation of the building previously occupied by RH Kelman Recycling Company. The renovated facility will be repurposed to serve as a storage space for equipment. Significant repairs are required to bring the building up to current health and safety standards.



# Schenectady County 2025 Capital Budget Request

**Request Year:** 2025

**Department:** Facilities

**Project Name:** 797 Broadway: Building Upgrades Phase 2

**Classification:** Project

**Type:** New



**Estimated Start:** 1/1/2025                      **Estimated Completion:** 12/31/2025

**Estimated Cost:** \$1,635,000

Federal Funding	State Funding	County Funding
\$0	\$0	\$1,635,000

**Project Description:**

797 Broadway Building Upgrades Part 2 will include the following:

- a.) Create a more welcoming waiting area and covered to keep clients out of the weather. This will extend the exterior vestibule creating a watertight and conditioned space for waiting patrons.
- b.) Replace exterior facade damaged from weather and vehicles.
- c.) Replacement of office furniture at 797 Broadway.
- d.) Continue floor renovations and replacement of worn or damaged carpet.

**Justification:**

- a.) The current exterior waiting space leaves patrons open to elements.
- b.) Pieces of exterior façade are deteriorating and causing trip hazards. Current signage is inadequate and not ADA appropriate.
- c.) Current furniture is at the end of its useful life. Some furniture is being held together by tape or pieces of wood screwed to some legs.
- d.) Current flooring, paint, signage, and bathrooms need full renovation & replacement.





# Schenectady County 2025 Capital Budget Request

**Request Year:** 2025  
**Department:** Facilities  
**Project Name:** 797 Broadway: HVAC Controls Change Out  
**Classification:** Project  
**Type:** New



**Estimated Start:** 1/1/2025                      **Estimated Completion:** 12/31/2025  
**Estimated Cost:** \$300,000

Federal Funding	State Funding	County Funding
\$0	\$0	\$300,000

**Project Description:**

In 2024, Facilities hired an engineering firm to look at the existing controls and how to best replace them for a more manageable and easy to use controls system.

Replace obsolete HVAC controls no longer serviceable.

**Justification:**

Current controls are in efficient and are causing constant vendor calls unnecessarily for simple change overs or issues.



# Schenectady County 2025 Capital Budget Request

**Request Year:** 2025

**Department:** Facilities

**Project Name:** Aviation: Roof Replacement Project at the Airport Tower

**Classification:** Project

**Type:** New



**Estimated Start:** 5/1/2025                      **Estimated Completion:** 10/1/2025

**Estimated Cost:** \$250,000

Federal Funding	State Funding	County Funding
\$0	\$0	\$250,000

**Project Description:**

The project involves the replacement of the existing rubber membrane roof and the rubber membrane on the catwalk that surrounds the tower cab.

**Justification:**

The current roof, now over 25 years old, has been subject to periodic leaks. Notably, the catwalk roof above the airport equipment room has been leaking, leading to water intrusion into the equipment area. This roof has reached the end of its service life and requires replacement to prevent further damage and ensure the protection of essential equipment.



# Schenectady County 2025 Capital Budget Request

**Request Year:** 2025  
**Department:** Facilities  
**Project Name:** Business Center: Fire Alarm Replacement  
**Classification:** Project  
**Type:** New



**Estimated Start:** 1/1/2025                      **Estimated Completion:** 12/31/2025  
**Estimated Cost:** \$100,000

Federal Funding	State Funding	County Funding
\$0	\$0	\$100,000

**Project Description:**

Replace outdated fire alarm panel at the Schenectady County Business Center

**Justification:**

Current system is outdated and needs to be replaced and brought up to code.



# Schenectady County 2025 Capital Budget Request

**Request Year:** 2025

**Department:** Facilities

**Project Name:** Courthouse & COB Fire System Separation Design Year

**Classification:** Project

**Type:** Replacement/Renewal

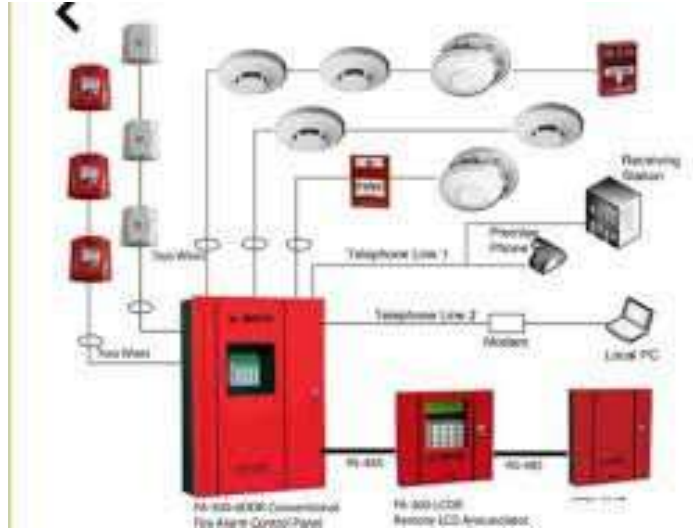

**Estimated Start:** 1/1/2025

**Estimated Completion:** 12/31/2025

**Estimated Cost:** \$70,000

Federal Funding	State Funding	County Funding
\$0	\$0	\$70,000

**Project Description:**

This study will look into the needed separation of the COB and Courthouse to have their own fire panel systems, this will include all new wiring, panels and devices. This will be the first phase needed for the next year to separate the buildings.

**Justification:**

Both buildings are required by code to have stand alone fire alarm systems.



# Schenectady County 2025 Capital Budget Request

**Request Year:** 2025

**Department:** Facilities

**Project Name:** Courthouse Basement  
Area & Mechanical Room  
Phase 3

**Classification:** Project

**Type:** Replacement/Renewal



**Estimated Start:** 1/1/2025

**Estimated Completion:** 12/31/2025

**Estimated Cost:** \$300,000

Federal Funding	State Funding	County Funding
\$0	\$0	\$300,000

### Project Description:

We will hire an abatement company to come in and abate above the ceiling and any necessary insulation. This will require some mechanical and electrical rewiring and piping during the abatement.

### Justification:

There is hazardous material above the ceiling and around associated piping which drives cost for repairs and modifications in the boiler room.



# Schenectady County 2025 Capital Budget Request

**Request Year:** 2025

**Department:** Facilities

**Project Name:** Courthouse: Boiler Room Project

**Classification:** Project

**Type:** New



**Estimated Start:** 1/1/2025                      **Estimated Completion:** 12/31/2025

**Estimated Cost:** \$300,000

Federal Funding	State Funding	County Funding
\$0	\$0	\$300,000

**Project Description:**

Update and replace pumps, motors and various outdated mechanical/electrical equipment including design.

**Justification:**

There are several pieces of mechanical and electrical equipment that are quickly nearing the end of their useful life, and it is imperative that we change these out to maintain all HVAC systems in the Courthouse.



# Schenectady County 2025 Capital Budget Request

**Request Year:** 2025  
**Department:** Facilities  
**Project Name:** Jail: Build Shed w/  
Lighting for Storage in  
Blue Lot  
**Classification:** Project  
**Type:** New



**Estimated Start:** 1/1/2025

**Estimated Completion:** 12/31/2025

**Estimated Cost:** \$15,000

Federal Funding	State Funding	County Funding
\$0	\$0	\$15,000

### Project Description:

Jail is in desperate need of storage.

### Justification:

Current jail facility does not have the proper amount of storage.



# Schenectady County 2025 Capital Budget Request

**Request Year:** 2025

**Department:** Facilities

**Project Name:** Jail: Cell Night Lights

**Classification:** Project

**Type:** New



**Estimated Start:** 1/1/2025

**Estimated Completion:** 12/31/2025

**Estimated Cost:** \$300,000

Federal Funding	State Funding	County Funding
\$0	\$0	\$300,000

**Project Description:**

As identified by jail administration, this area of the cell is very dark which creates a security risk.

**Justification:**

The addition of night lights will create proper illumination and supervision over inmates by jail staff, allowing them to better react if needed.





# Schenectady County 2025 Capital Budget Request

**Request Year:** 2025  
**Department:** Facilities  
**Project Name:** Jail: Dorm Windows Replacement  
**Classification:** Project  
**Type:** Replacement/Renewal



**Estimated Start:** 1/1/2025                      **Estimated Completion:** 12/31/2025  
**Estimated Cost:** \$500,000

Federal Funding	State Funding	County Funding
\$0	\$0	\$500,000

**Project Description:**

Current windows provide a security risk with hiding places for contraband. Jail administration wants them replaced as soon as possible.

**Justification:**

Current windows are not safe and secure and at the end of their lifespan.



# Schenectady County 2025 Capital Budget Request

**Request Year:** 2025  
**Department:** Facilities  
**Project Name:** Jail: Drains and Penthouse  
**Classification:** Project  
**Type:** Replacement/Renewal



**Estimated Start:** 1/1/2025                      **Estimated Completion:** 12/31/2025  
**Estimated Cost:** \$50,000

Federal Funding	State Funding	County Funding
\$0	\$0	\$50,000

**Project Description:**

Review and repair non-functioning drains.

**Justification:**

There are numerous drains that are either not working or broken that need to get repaired.



# Schenectady County 2025 Capital Budget Request

**Request Year:** 2025

**Department:** Facilities

**Project Name:** Jail: Fires Sprinkler Head Change Out



**Classification:** Project

**Type:** New

**Estimated Start:** 1/1/2025

**Estimated Completion:** 12/31/2025

**Estimated Cost:** \$75,000

Federal Funding	State Funding	County Funding
		\$75,000

**Project Description:**

Changing out different sprinkler heads in the cells and open space areas to approved sprinkler heads for correctional facilities.

**Justification:**

Changing out outdated sprinkler heads to correctional facility approved heads.



# Schenectady County 2025 Capital Budget Request

**Request Year:** 2025  
**Department:** Facilities  
**Project Name:** Jail: Flush Valves Phase 2  
**Classification:** Project  
**Type:** Replacement/Renewal



**Estimated Start:** 1/1/2025                      **Estimated Completion:** 12/31/2025

**Estimated Cost:** \$500,000

Federal Funding	State Funding	County Funding
\$0	\$0	\$500,000

### **Project Description:**

Continuation of Phase 1, this project will continue to change our current inmate flush valves to tamper-proof.

### **Justification:**

With the current flush valves, inmates are able to flush multiple times in a short timespan which backs up, causing the toilets to overflow and water to spill everywhere, resulting in significant damage to the floor below. These new valves are designed to be in a jail and have a timing system where they will not be able to do this.



# Schenectady County 2025 Capital Budget Request

**Request Year:** 2025  
**Department:** Facilities  
**Project Name:** Jail: Repair Brick w/  
Stainless Steel Guard  
Exterior Visitor Area  
**Classification:** Project  
**Type:** Replacement/Renewal



**Estimated Start:** 1/1/2025                      **Estimated Completion:** 12/31/2025  
**Estimated Cost:** \$30,000

Federal Funding	State Funding	County Funding
\$0	\$0	\$30,000

### Project Description:

In the Sally Port, the exterior brick of the building coming through the gate needs to be replaced and repointed, and a steel guard add to properly protect the building from damage.

### Justification:

Corner of building in sally port constantly gets hit/damaged by delivery trucks.



# Schenectady County 2025 Capital Budget Request

**Request Year:** 2025  
**Department:** Facilities  
**Project Name:** Jail: Sally Port W1 Gate  
Demolition & Replacement  
**Classification:** Project  
**Type:** Replacement/Renewal



**Estimated Start:** 1/1/2025                      **Estimated Completion:** 12/31/2025  
**Estimated Cost:** \$125,000

Federal Funding	State Funding	County Funding
\$0	\$0	\$125,000

**Project Description:**

Have a contractor come in and replace the main gate and associated controls.

**Justification:**

Existing gate is at the end of its useful life. For proper security, it needs to be replaced.



# Schenectady County 2025 Capital Budget Request

**Request Year:** 2025

**Department:** Facilities

**Project Name:** Library: Bookdrops Project

**Classification:** Project

**Type:** New



**Estimated Start:** 1/1/2025                      **Estimated Completion:** 12/31/2025

**Estimated Cost:** \$50,000

Federal Funding	State Funding	County Funding
\$0	\$0	\$50,000

**Project Description:**

Rotterdam - Drive-up book drop box, Woodlawn - book drop, Mont Pleasant - book drop, Niskayuna - Book drop, Glenville - Book drop, Scotia - Book drop, KBJ - Book drop

**Justification:**

The addition of drive up book drops allows for faster returns and accessibility for patrons that can not walk long distances.



# Schenectady County 2025 Capital Budget Request

**Request Year:** 2025

**Department:** Facilities

**Project Name:** Library: Fire Panels Phase 2

**Classification:** Project

**Type:** New



**Estimated Start:** 1/1/2025                      **Estimated Completion:** 12/31/2025

**Estimated Cost:** \$200,000

Federal Funding	State Funding	County Funding
\$0	\$0	\$200,000

**Project Description:**

Continuation for the replacing of old and outdated fire alarm systems at the libraries.

**Justification:**

For health and safety, it is important to replace old and obsolete panels to meet code. As we continue to upgrade these panels, it will also help minimize maintenance calls.





# Schenectady County 2025 Capital Budget Request

**Request Year:** 2025

**Department:** Facilities

**Project Name:** Library: Signage Project Phase 1

**Classification:** Project

**Type:** New



**Estimated Start:** 1/1/2025                      **Estimated Completion:** 12/31/2025

**Estimated Cost:** \$60,000

Federal Funding	State Funding	County Funding
\$0	\$0	\$60,000

**Project Description:**

Rotterdam - signage, Woodlawn - signage building/monument, Niskayuna - signage, Glenville - signage, KBJ signage

**Justification:**

Current signage is unreadable or missing and does not tell you what building you are at.



# Schenectady County 2025 Capital Budget Request

**Request Year:** 2025

**Department:** Facilities

**Project Name:** Library: Woodlawn Library  
Feasibility Study for  
Quaker & Woodlawn  
Expansion

**Classification:** Project

**Type:** New



**Estimated Start:** 1/1/2025

**Estimated Completion:** 12/31/2025

**Estimated Cost:** \$75,000

Federal Funding	State Funding	County Funding
\$0	\$0	\$75,000

**Project Description:**

Feasibility study for additional program room, possible land purchase or parking lease to accommodate expansion at Woodlawn & Quaker.

**Justification:**

Current program space is inadequate for current patron attendance.



# Schenectady County 2025 Capital Budget Request

**Request Year:** 2025

**Department:** Facilities

**Project Name:** Unified Communication  
Center: HVAC upgrade  
Phase 1

**Classification:** Project

**Type:** New

**Estimated Start:** 1/1/2025

**Estimated Completion:** 12/31/2025

**Estimated Cost:** \$75,000



Federal Funding	State Funding	County Funding
\$0	\$0	\$75,000

**Project Description:**

Replace dated HVAC equipment.

**Justification:**

Current HVAC condensers are faulty and are intermittently causing problems at a high-risk facility.



# Schenectady County 2025 Capital Budget Request

**Request Year:** 2025  
**Department:** Glendale Nursing Home  
**Project Name:** Glendale: Garage  
**Classification:** Project  
**Type:** New



**Estimated Start:** 1/1/2025                      **Estimated Completion:** 12/31/2025  
**Estimated Cost:** \$500,000

Federal Funding	State Funding	County Funding
\$0	\$0	\$500,000

**Project Description:**

Garage needed for storage of landscaping equipment.

**Justification:**

Current garage no longer useable at current location.



# Schenectady County 2025 Capital Budget Request

**Request Year:** 2025  
**Department:** Information Services  
**Project Name:** IT Security Tools  
**Classification:** Project  
**Type:** New



**Estimated Start:** 1/1/2025                      **Estimated Completion:** 12/31/2025  
**Estimated Cost:** \$70,000

Federal Funding	State Funding	County Funding
\$0	\$0	\$70,000

**Project Description:**

IT Security Tools. Implementation of new security software.

**Justification:**

Tools to strengthen and enhance Schenectady County's security posture.



# Schenectady County 2025 Capital Budget Request

**Request Year:** 2025

**Department:** Schenectady County  
Community College

**Project Name:** Begley Basement  
Renovation

**Classification:** Project

**Type:** Replacement/Renewal



**Estimated Start:** 4/1/2025                      **Estimated Completion:** 6/30/2026

**Estimated Cost:** \$1,500,000

Federal Funding	State Funding	County Funding
\$0	\$750,000	\$750,000

**Project Description:**

Replacement of the Begley Basement Garage Floor and peripherals.

**Justification:**

The Begley Basement is in poor shape due to water intrusion and poor construction. Metal rebar is protruding through the basement floor surface creating a tripping hazard and overall floor deterioration. A study of the basement was conducted in 2023-24 determining the drainage systems, floor and subsurface require replacement.



# Schenectady County 2025 Capital Budget Request

**Request Year:** 2025

**Department:** Schenectady County  
Community College

**Project Name:** Culinary Program Kitchen  
Ventilation & Dining Room  
Renovation

**Classification:** Project

**Type:** Existing



**Estimated Start:** 4/1/2025                      **Estimated Completion:** 6/30/2026

**Estimated Cost:** \$600,000

Federal Funding	State Funding	County Funding
\$0	\$300,000	\$300,000

**Project Description:**

Replacement of failed kitchen air ventilation systems and renovation of the culinary dining room.

**Justification:**

The ventilation systems in the culinary banquet kitchens have failed and require replacement. Ventilation is necessary to exhaust fumes and harmful smoke. Project also includes renovation of the culinary dining room which is in need of restoration due to age and outdated finishes.



# Schenectady County 2025 Capital Budget Request

**Request Year:** 2025

**Department:** Schenectady County  
Community College

**Project Name:** Elston Hall: Gathering  
Area and Kitchen  
Renovation

**Classification:** Project

**Type:** Existing



**Estimated Start:** 4/1/2025                      **Estimated Completion:** 6/30/2026

**Estimated Cost:** \$1,250,000

Federal Funding	State Funding	County Funding
\$0	\$625,000	\$625,000

**Project Description:**

Replacement of outdated commercial kitchen equipment, floors, ceilings and utilities in the cafeteria area and renovation of the large cafeteria/gathering area in Elston Hall

**Justification:**

The cafeteria kitchen area constructed in 1992 has exceeded its useful life. Commercial kitchen equipment is failing and cannot be repaired. Ceiling, floor and wall finishes require replacement. The gathering/cafeteria area is being converted into a usable space for student use and activities.





# Schenectady County 2025 Capital Budget Request

**Request Year:** 2025

**Department:** Schenectady County  
Community College

**Project Name:** Mechanical, Electrical,  
and Plumbing Study

**Classification:** Project

**Type:** Study/Design



**Estimated Start:** 4/1/2025                      **Estimated Completion:** 6/30/2026

**Estimated Cost:** \$50,000

Federal Funding	State Funding	County Funding
\$0	\$25,000	\$25,000

**Project Description:**

Development of a 5 to 10 year Mechanical, Electrical and Plumbing (MEP) facilities master plan to forecast future capital project needs to maintain the college's physical plant.

**Justification:**

The college's physical plant ranges in age from 25 to 100 years old requiring frequent maintenance and capital investments. A comprehensive MEP study will provide a guide for future capital projects to ensure facilities are in good working order and to help forecast capital cost investment.

# **CAPITAL EQUIPMENT REQUESTS 2025**



# Schenectady County 2025 Capital Budget Request

**Request Year:** 2025  
**Department:** Board of Elections  
**Project Name:** New Voting Machines  
**Classification:** Equipment  
**Type:** Replacement/Renewal



**Estimated Start:** 3/1/2025                      **Estimated Completion:** 12/31/2025  
**Estimated Cost:** \$1,000,000

Federal Funding	State Funding	County Funding
\$0	\$0	\$1,000,000

**Project Description:**

New voting machines for the county in addition to new software to support.

**Justification:**

Current voting machines are at end of life. If grant money becomes available, the amount requested from the county will be reduced.



# Schenectady County 2025 Capital Budget Request

**Request Year:** 2025

**Department:** Engineering and Public Works

**Project Name:** DEPW: Refurbish Equipment

**Classification:** Equipment

**Type:** Replacement/Renewal



**Estimated Start:** 1/1/2025                      **Estimated Completion:** 12/31/2025

**Estimated Cost:** \$100,000

Federal Funding	State Funding	County Funding
\$0	\$0	\$100,000

**Project Description:**

Refurbishment will be completed on multiple trucks along with multiple plows & wings

**Justification:**

To extend the useful life of these units by a minimum of 5 years



# Schenectady County 2025 Capital Budget Request

**Request Year:** 2025

**Department:** Engineering and Public Works

**Project Name:** Equipment Replacement:  
New TCX 635 PHD Large  
Truck Tire Changer

**Classification:** Equipment

**Type:** Replacement/Renewal



**Estimated Start:** 1/1/2025                      **Estimated Completion:** 12/31/2025

**Estimated Cost:** \$47,000

Federal Funding	State Funding	County Funding
\$0	\$0	\$47,000

**Project Description:**

New TCX 635 PHD large truck tire changer from Hunter Engineering Company and New 2025 TC 395SW Car & Light Truck Tire Changer for DEPW.

**Justification:**

This large truck tire changer unit will replace the current one which is 20 years old and becoming increasingly difficult to get parts for. The car and light truck changer currently in use is 16 years old and not as efficient as it once was.



# Schenectady County 2025 Capital Budget Request

**Request Year:** 2025

**Department:** Engineering and Public Works

**Project Name:** Equipment: New 2025 Guardrail Post Pounder, GRT Utilicorp

**Classification:** Equipment

**Type:** Replacement/Renewal



**Estimated Start:** 1/1/2025                      **Estimated Completion:** 12/31/2025

**Estimated Cost:** \$255,000

Federal Funding	State Funding	County Funding
\$0	\$0	\$255,000

**Project Description:**

New 2025 Guardrail Post Pounder, GRT Utilicorp

**Justification:**

This will replace 1015/1287 a 1994 post pounder which has a lot of wear and tear, leaking valves, many hours on it and needs to be replaced.





# Schenectady County 2025 Capital Budget Request

**Request Year:** 2025

**Department:** Engineering and Public Works

**Project Name:** Fleet Replacement:  
General County Inventory

**Classification:** Equipment

**Type:** Replacement/Renewal



**Estimated Start:** 1/1/2025                      **Estimated Completion:** 12/31/2025

**Estimated Cost:** \$395,000

Federal Funding	State Funding	County Funding
\$0	\$0	\$395,000

**Project Description:**

The Department of Engineering and Public Works manages the County fleet and recommends when replacement of vehicles is necessary. The County vehicle fleet is managed as one large pool of vehicles and assigned as needed.

For the list of vehicles to be purchased, please see the Vehicle Fleet Replacement table on page 6.

**Justification:**

These will replace vehicles that are nearing their end-of-life.





# Schenectady County 2025 Capital Budget Request

**Request Year:** 2025

**Department:** Engineering and Public Works

**Project Name:** Fleet Replacement: MV 607 SBA 4x2 Crew Truck with Dump Body

**Classification:** Equipment

**Type:** Replacement/Renewal



**Estimated Start:** 1/1/2025                      **Estimated Completion:** 12/31/2025

**Estimated Cost:** \$145,000

Federal Funding	State Funding	County Funding
\$0	\$0	\$145,000

### Project Description:

MV 607 SBA 4x2 Crew Truck with Dump Body

### Justification:

This new unit will replace 1049, a 2011 4300 International with approx. 180,000 miles at the time of replacement. 1049 will replace 1048 which is being used for a water truck. 1048 will be used as an extra for now, it may go to auction in the future.



# Schenectady County 2025 Capital Budget Request

**Request Year:** 2025

**Department:** Engineering and Public Works

**Project Name:** Fleet Replacement: New 2025 DD25B Volvo Asphalt Roller

**Classification:** Equipment

**Type:** Replacement/Renewal



**Estimated Start:** 1/1/2025                      **Estimated Completion:** 12/31/2025

**Estimated Cost:** \$52,000

Federal Funding	State Funding	County Funding
\$0	\$0	\$52,000

**Project Description:**

New 2025 DD25B Volvo Asphalt Roller

**Justification:**

This unit will replace 1261, a 1990 Ingersol road roller which has over 3100 hours on it and is 34 years old. This unit will go to auction.



# Schenectady County 2025 Capital Budget Request

**Request Year:** 2025

**Department:** Engineering and Public Works

**Project Name:** Fleet Replacement: New 2025 HV507 SFA Single Axle Dump Truck

**Classification:** Equipment

**Type:** Replacement/Renewal

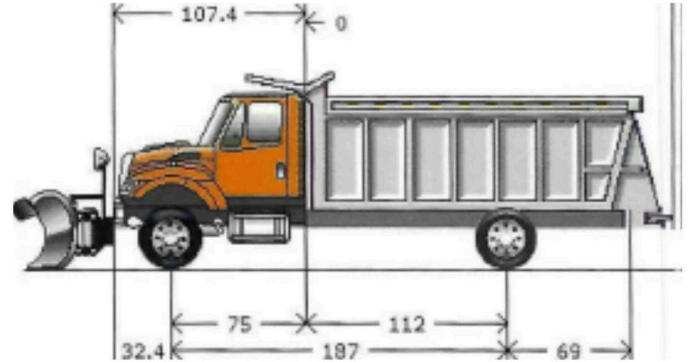

**HV507**

**Estimated Start:** 1/1/2025                                      **Estimated Completion:** 12/31/2025

**Estimated Cost:** \$275,000

Federal Funding	State Funding	County Funding
\$0	\$0	\$275,000

**Project Description:**

New 2025 HV507 SFA single axle dump truck with snow & ice equipment, auto chains, 2-way radio

**Justification:**

This will replace 1152, a 2011 International with approximately 95,000 miles at time of replacement. Vehicle 1152 will become a spare.



# Schenectady County 2025 Capital Budget Request

**Request Year:** 2025

**Department:** Engineering and Public Works

**Project Name:** Fleet Replacement: New 2025 HX520 SFA Tandem Dump Truck

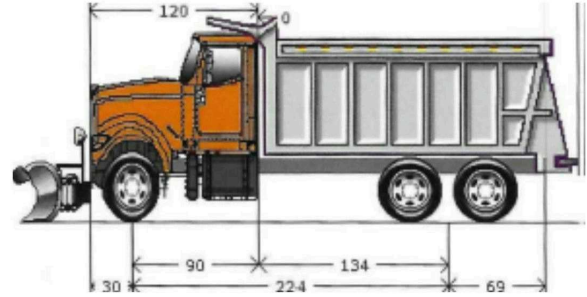

**Classification:** Equipment

**HX520**

**Type:** Replacement/Renewal

**Estimated Start:** 1/1/2025

**Estimated Completion:** 12/31/2025

**Estimated Cost:** \$330,000

Federal Funding	State Funding	County Funding
\$0	\$0	\$330,000

**Project Description:**

New 2025 HX520 SFA Tandem dump truck with snow & ice equip., auto chains, 2-way radio

**Justification:**

This will replace 1155 and that will become a spare.



# Schenectady County 2025 Capital Budget Request

**Request Year:** 2025

**Department:** Engineering and Public Works

**Project Name:** Fleet Replacement: New 2025 International Dump Truck 6x6

**Classification:** Equipment

**Type:** Replacement/Renewal

**Estimated Start:** 1/1/2025

**Estimated Completion:** 12/31/2025

**Estimated Cost:** \$300,000

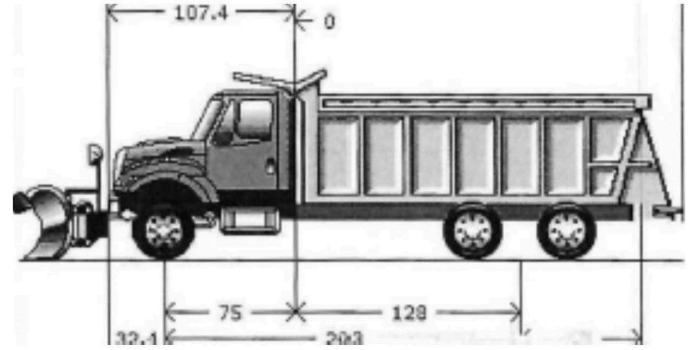

Federal Funding	State Funding	County Funding
\$0	\$0	\$300,000

**Project Description:**

New 2025 International dump truck 6x6 with snow & ice equipment, auto chains, 2-way radio

**Justification:**

This will replace unit 1148, a 2008 International Paystar 6x6 with 116,000 miles at the time of replacement. Vehicle 1148 will be 16 years old and will be used for a spare.



# Schenectady County 2025 Capital Budget Request

**Request Year:** 2025

**Department:** Engineering and Public Works

**Project Name:** Fleet Replacement: New 2025 T66 T4 Bobcat Compact Track Loader

**Classification:** Equipment

**Type:** Replacement/Renewal



**Estimated Start:** 1/1/2025                      **Estimated Completion:** 12/31/2025

**Estimated Cost:** \$78,000

Federal Funding	State Funding	County Funding
\$0	\$0	\$78,000

**Project Description:**

New 2025 T66 T4 Bobcat Compact Track Loader with additional features

**Justification:**

This unit will replace 1284, a 1996 Bobcat loader with 2100 hours and 28 years old and will go to auction.



# Schenectady County 2025 Capital Budget Request

**Request Year:** 2025

**Department:** Engineering and Public Works

**Project Name:** Fleet Replacement: New 2025 Volvo ECR88D Excavator

**Classification:** Equipment

**Type:** Replacement/Renewal



**Estimated Start:** 1/1/2025 **Estimated Completion:** 12/31/2025

**Estimated Cost:** \$132,000

Federal Funding	State Funding	County Funding
\$0	\$0	\$132,000

**Project Description:**

New 2025 Volvo ECR88D Excavator

**Justification:**

This unit will replace 1238 a 1994 JCB Backhoe which is 30 years old, has 3200 hours on it and has electrical issues. Unit 1245 will take its place and this new unit will take 1245's place. Unit 1238 will go to auction.



# Schenectady County 2025 Capital Budget Request

**Request Year:** 2025

**Department:** Glendale Nursing Home

**Project Name:** Fleet Replacement:  
Glendale 2025 2500  
Chevy or Ford F-250

**Classification:** Equipment

**Type:** Replacement/Renewal



**Estimated Start:** 1/1/2025                      **Estimated Completion:** 12/31/2025

**Estimated Cost:** \$59,000

Federal Funding	State Funding	County Funding
\$0	\$0	\$59,000

**Project Description:**

2025 2500 Chevy or Ford F-250 Regular Cab with V-Plow

**Justification:**

Unit 2426 will be 25 years old at the time of replacement and has significant rusting. Unit 2426 will go to auction.





# Schenectady County 2025 Capital Budget Request

**Request Year:** 2025

**Department:** Glendale Nursing Home

**Project Name:** Nurse Call Bell System for 1 Unit

**Classification:** Equipment

**Type:** Replacement/Renewal



**Estimated Start:** 1/1/2025                                      **Estimated Completion:** 12/31/2025

**Estimated Cost:** \$50,750

Federal Funding	State Funding	County Funding
\$0	\$0	\$50,750

**Project Description:**

Nurse Call Bell System for 1 Unit

**Justification:**

To replace aging Nurse Call System on another unit. The parts for our current system are no longer manufacturer. Service calls to have technicians come on-site to assist with troubleshooting the system cost significantly more since the system has been discontinued by the manufacturer.



# Schenectady County 2025 Capital Budget Request

**Request Year:** 2025  
**Department:** Information Services  
**Project Name:** Network Switch Upgrade  
**Classification:** Equipment  
**Type:** Replacement/Renewal



**Estimated Start:** 1/1/2025                      **Estimated Completion:** 12/31/2025  
**Estimated Cost:** \$100,000

Federal Funding	State Funding	County Funding
\$0	\$0	\$100,000

**Project Description:**

Implement network switch upgrades.

**Justification:**

Replace network switches as needed based on age.



# Schenectady County 2025 Capital Budget Request

**Request Year:** 2025

**Department:** Information Services

**Project Name:** Network Test Equipment

**Classification:** Equipment

**Type:** Existing



**Estimated Start:** 1/1/2025                      **Estimated Completion:** 12/31/2025

**Estimated Cost:** \$45,000

Federal Funding	State Funding	County Funding
\$0	\$0	\$45,000

**Project Description:**

Purchase network test equipment.

**Justification:**

Equipment required to test and scan network.



# Schenectady County 2025 Capital Budget Request

**Request Year:** 2025  
**Department:** Purchasing  
**Project Name:** Copiers and Equipment  
**Classification:** Equipment  
**Type:** Replacement/Renewal



**Estimated Start:** 1/1/2025                      **Estimated Completion:** 12/31/2025  
**Estimated Cost:** \$30,000

Federal Funding	State Funding	County Funding
\$0	\$0	\$30,000

**Project Description:**

Replacement of copiers and other large office equipment.

**Justification:**

As office equipment ages out, or fails, new equipment must be purchased. This capital fund will be available to replace a copier or items of this nature.



# Schenectady County 2025 Capital Budget Request

**Request Year:** 2025  
**Department:** Sheriff - All Divisions  
**Project Name:** Sheriff Dept.: 2025 Ford Explorer for Task Force Unit  
**Classification:** Equipment  
**Type:** New



**Estimated Start:** 1/1/2025                      **Estimated Completion:** 12/31/2025  
**Estimated Cost:** \$65,000

Federal Funding	State Funding	County Funding
\$0	\$0	\$65,000

**Project Description:**

Task Force unit - 2025 Ford Explorer with standard features and emergency lights.

**Justification:**

New to the fleet - for the Task Force.



# Schenectady County 2025 Capital Budget Request

**Request Year:** 2025

**Department:** Sheriff - All Divisions

**Project Name:** Sheriff Dept.: Vehicle Replacements and Upfitting

**Classification:** Equipment

**Type:** New



**Estimated Start:** 1/1/2025                      **Estimated Completion:** 12/31/2025

**Estimated Cost:** \$304,000

Federal Funding	State Funding	County Funding
\$0	\$0	\$304,000

**Project Description:**

The Department of Engineering and Public Works manages the Sheriff's Department's fleet and recommends when replacement of vehicles is necessary. For 2025, the Sheriff's request is for:

- Three (3) Patrol Interceptors with upfitting. Upfitting will include Panasonic Toughbook laptops and docking stations.
- One (1) Chevy 3500 Express Van with standard options and police features.

**Justification:**

These Interceptors will potentially replace vehicles that are nearing their end-of-life. (#2389 and #2360)  
 The Chevy Van will replace 2378, which will have approx. 150,000 miles at time of replacement. 2378 will replace 3612, a 2005 Chevy Express Van that will go to auction.

**FUTURE CAPITAL PLAN REQUESTS  
2026-2030**



# Schenectady County 2025 Capital Budget Request

**Request Year:** 2026

**Department:** Facilities

**Project Name:** Business Center: Exterior Rehabilitation

**Classification:** Project

**Type:** New

**Estimated Start:** 1/1/2026

**Estimated Completion:** 12/31/2026

**Estimated Cost:** \$150,000



Federal Funding	State Funding	County Funding
\$0	\$0	\$150,000

**Project Description:**

Exterior dryvit is stained badly which makes it unsightly.

**Justification:**

Fixing exterior dryvit will improve building condition.





# Schenectady County 2025 Capital Budget Request

**Request Year:** 2026  
**Department:** Facilities  
**Project Name:** Business Center: Interior Upgrades  
**Classification:** Project  
**Type:** Replacement/Renewal



**Estimated Start:** 1/1/2026                      **Estimated Completion:** 12/31/2026  
**Estimated Cost:** \$30,000

Federal Funding	State Funding	County Funding
\$0	\$0	\$30,000

**Project Description:**

Install crash rails and FRP in all common area hallways.

**Justification:**

To prevent further damage to interior walls from pallet jacks and other machinery.



# Schenectady County 2025 Capital Budget Request

**Request Year:** 2026

**Department:** Facilities

**Project Name:** County Office Building:  
Streetscape Phase 2  
(Courthouse & 608 State)

**Classification:** Project

**Type:** New



**Estimated Start:** 1/1/2026                      **Estimated Completion:** 12/31/2026

**Estimated Cost:** \$750,000

Federal Funding	State Funding	County Funding
\$0	\$0	\$750,000

**Project Description:**

Courthouse Façade Restoration and 608 State Street Ramp and Façade Work. This involves adding stabilization or removal of the upper floor porches.

**Justification:**

The Courthouse needs to have restorative work completed in numerous areas of the building. The 608 State Street retaining wall, ramp, and exterior façade work are in need of attention. The Front of the County Office Building and Courthouse need restorative work and fixing of patio pavers.



# Schenectady County 2025 Capital Budget Request

**Request Year:** 2026

**Department:** Facilities

**Project Name:** Courthouse Exterior  
Masonry

**Classification:** Project

**Type:** Replacement/Renewal



**Estimated Start:** 1/1/2026                      **Estimated Completion:** 12/31/2026

**Estimated Cost:** \$1,000,000

Federal Funding	State Funding	County Funding
\$0	\$0	\$1,000,000

**Project Description:**

Phase 1 of mason exterior repairs as mentioned in the four-building survey study. Replace limestone, brick and mortar repairs patch as needed.

**Justification:**

As part of restorative maintenance to the Courthouse to prevent falling debris and increase lighting to create a secure environment. The back of the courthouse brick façade is bowing and showing signs of extreme water infiltration, this is a safety concern and needs to be addressed.



# Schenectady County 2025 Capital Budget Request

**Request Year:** 2026  
**Department:** Facilities  
**Project Name:** Courthouse Facade Renovation  
**Classification:** Project  
**Type:** New



**Estimated Start:** 1/1/2026                      **Estimated Completion:** 12/31/2026  
**Estimated Cost:** \$1,000,000

Federal Funding	State Funding	County Funding
\$0	\$0	\$1,000,000

**Project Description:**

Routine Maintenance and Repairs of the Cast Stone and Cornices

**Justification:**

As the building ages, it is necessary to do repairs and replacements of certain cast stone pieces. The higher up these pieces are, the harder it is to replace. With the guidance of the Building Survey, this will be a routine maintenance for the next 5 years.



# Schenectady County 2025 Capital Budget Request

**Request Year:** 2026

**Department:** Facilities

**Project Name:** Courthouse Lobby refresh  
PH1 & Reimagine Historic

**Classification:** Project

**Type:** Replacement/Renewal



**Estimated Start:** 1/1/2026

**Estimated Completion:** 12/31/2026

**Estimated Cost:** \$1,500,000

Federal Funding	State Funding	County Funding
\$0	\$0	\$1,500,000

**Project Description:**

Bring lobby back to historical look and feel.

**Justification:**

Interior finishes are tired and mask historic value of the Courthouse.



# Schenectady County 2025 Capital Budget Request

**Request Year:** 2026

**Department:** Facilities

**Project Name:** Courthouse: Bathroom Renovation Phase 2

**Classification:** Project

**Type:** New



**Estimated Start:** 1/1/2026                      **Estimated Completion:** 12/31/2026

**Estimated Cost:** \$500,000

Federal Funding	State Funding	County Funding
\$0	\$0	\$500,000

**Project Description:**

Continuation of replacing shared space bathrooms.

**Justification:**

Current fixtures and bathrooms are antiquated and some fixtures are broken, some piping and drains have to get replaced or relined due to age. Facilities started this in 2024 and is continuing through the rest of the courthouse.



# Schenectady County 2025 Capital Budget Request

**Request Year:** 2026  
**Department:** Facilities  
**Project Name:** Courthouse: Electrical Panel Upgrades  
**Classification:** Project  
**Type:** New



**Estimated Start:** 1/1/2026                      **Estimated Completion:** 12/31/2026  
**Estimated Cost:** \$750,000

Federal Funding	State Funding	County Funding
\$0	\$0	\$750,000

**Project Description:**

Replacing electrical panels and conduit in the Courthouse.

**Justification:**

The existing panels are nearing the end of their useful life and will need to be replaced.



# Schenectady County 2025 Capital Budget Request

**Request Year:** 2026

**Department:** Facilities

**Project Name:** Courthouse: Exterior Rehabilitation

**Classification:** Project

**Type:** New



**Estimated Start:** 1/1/2026                      **Estimated Completion:** 12/31/2026

**Estimated Cost:** \$750,000

Federal Funding	State Funding	County Funding
\$0	\$0	\$750,000

**Project Description:**

Repairing broken/cracked/failing stonework along the Courthouse facade, replacing railings, replacing doors, and fixing up the skybridge connecting the jail and the courthouse.

**Justification:**

Starting with the back and side of the Courthouse, there is façade, brick, and drainage work that needs to be designed and restored. The skybridge connected to the back of the courthouse needs to be power washed, painted, and have some roof restoration due to improper drainage





# Schenectady County 2025 Capital Budget Request

**Request Year:** 2026

**Department:** Facilities

**Project Name:** DEPW: Roof Replacement  
Barrel Vault Roof



**Classification:** Project

**Type:** New

**Estimated Start:** 1/1/2026

**Estimated Completion:** 12/31/2026

**Estimated Cost:** \$1,500,000

Federal Funding	State Funding	County Funding
\$0	\$0	\$1,500,000

**Project Description:**

Replacement of the barrel vault roofs over the highway garages.

**Justification:**

The current roof on both garages has exceed its useful life, currently it has several leaks damaging new insulation and is beyond repairable.



# Schenectady County 2025 Capital Budget Request

**Request Year:** 2026

**Department:** Facilities

**Project Name:** Jail: Booking Area Refresh

**Classification:** Project

**Type:** New



**Estimated Start:** 1/1/2026                      **Estimated Completion:** 12/31/2026

**Estimated Cost:** \$400,000

Federal Funding	State Funding	County Funding
\$0	\$0	\$400,000

**Project Description:**

Replace current flooring with durable finishes and revamping paint, ceilings and lights in the processing area.

**Justification:**

Current processing area is tired paint peeling off floor and walls and ceiling, not enough lights and area is need of reconfiguration for better process flow.



# Schenectady County 2025 Capital Budget Request

**Request Year:** 2026

**Department:** Facilities

**Project Name:** Jail: Dorm Hallway Refresh

**Classification:** Project

**Type:** Replacement/Renewal



**Estimated Start:** 1/1/2026

**Estimated Completion:** 12/31/2026

**Estimated Cost:** \$150,000

Federal Funding	State Funding	County Funding
\$0	\$0	\$150,000

**Project Description:**

Hallway walls are in need of repair FRP paneling falling off walls.

**Justification:**

Paneling can break off and fall down creating a hazardous work environment, needs to be replaced.



# Schenectady County 2025 Capital Budget Request

**Request Year:** 2026

**Department:** Facilities

**Project Name:** Jail: Epoxy Floors 1-4  
Phase 3

**Classification:** Project

**Type:** Replacement/Renewal



**Estimated Start:** 1/1/2026                      **Estimated Completion:** 12/31/2026

**Estimated Cost:** \$500,000

Federal Funding	State Funding	County Funding
\$0	\$0	\$500,000

**Project Description:**

This project is the continuation of the Jail Epoxy Flooring Phase 1 project, changing jail flooring from old VCT to epoxy flooring.

**Justification:**

Epoxy creates a water tight seal and does not break off into dangerous shards. It adheres to the concrete for a 30-50 year finish that can withstand a rough environment. This flooring will be easier to clean and maintain for the facility.



# Schenectady County 2025 Capital Budget Request

**Request Year:** 2026

**Department:** Facilities

**Project Name:** Jail: Exterior Phase 3

**Classification:** Project

**Type:** Replacement/Renewal

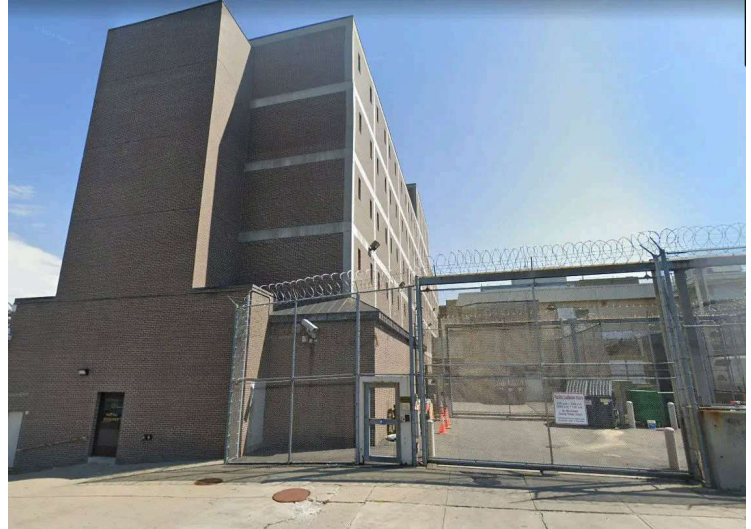

**Estimated Start:** 1/1/2026                      **Estimated Completion:** 12/31/2026

**Estimated Cost:** \$175,000

Federal Funding	State Funding	County Funding
\$0	\$0	\$175,000

**Project Description:**

Visitor entrance door, need an ADA ramp and will need to create a flat spot, concrete apron leaving back of jail lot needs to be redone.

**Justification:**

To meet ADA requirements and correct current safety hazards.



# Schenectady County 2025 Capital Budget Request

**Request Year:** 2026

**Department:** Facilities

**Project Name:** Jail: In Depth Design  
Study of the Jail



**Classification:** Project

**Type:** Study/Design

**Estimated Start:** 1/1/2026

**Estimated Completion:** 12/31/2026

**Estimated Cost:** \$65,000

Federal Funding	State Funding	County Funding
\$0	\$0	\$65,000

**Project Description:**

A comprehensive study can inform long-term planning efforts by identifying not only immediate needs but also anticipated future requirements for correctional officer workspaces. This can help ensure that investments in workspace refreshment are aligned with the facility's strategic goals and budgetary constraints.

**Justification:**

In conclusion, a more in-depth study can provide the evidence-based rationale and justification needed to support the refreshment of spaces in jails for staff and inmates, ensuring that resources are allocated effectively and that the initiative contributes to the overall well-being and effectiveness of correctional staff and the institution as a whole.



# Schenectady County 2025 Capital Budget Request

**Request Year:** 2026  
**Department:** Facilities  
**Project Name:** Jail: Locker Room and Administrative Area Refresh  
**Classification:** Project  
**Type:** New



**Estimated Start:** 1/1/2026                      **Estimated Completion:** 12/31/2026  
**Estimated Cost:** \$750,000

Federal Funding	State Funding	County Funding
\$0	\$0	\$750,000

### Project Description:

Design started in 2024 for construction but due to the extent of necessary repairs, we will need additional funding to complete the project.

### Justification:

The current locker rooms need a complete gut in order to incorporate the necessary repairs and install gender neutral locker room space in the locker room area.



# Schenectady County 2025 Capital Budget Request

**Request Year:** 2026

**Department:** Facilities

**Project Name:** Jail: Locker Room Phase 2  
and Administration Area

**Classification:** Project

**Type:** Replacement/Renewal

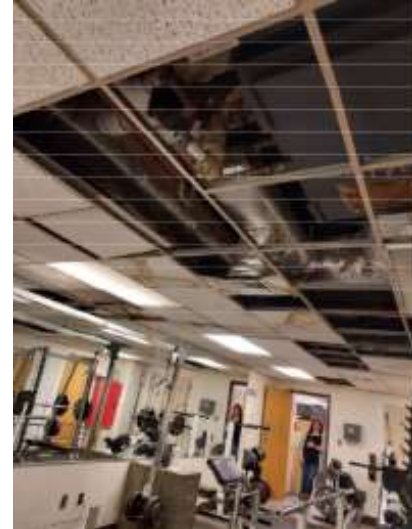

**Estimated Start:** 1/1/2026

**Estimated Completion:** 12/31/2026

**Estimated Cost:** \$750,000

Federal Funding	State Funding	County Funding
\$0	\$0	\$750,000

## Project Description:

In 2024, Facilities started the design for the Jail Locker room project but as we started looking into ceilings and piping, it was determined that we would quickly be over budget with the necessary repairs and replacements that need to be made.

## Justification:

The Jail locker room is located on the same floor as the Jail Administration in the original (or "old") part of the jail. By refreshing the space, it will improve moral in a high stress field environment.





# Schenectady County 2025 Capital Budget Request

**Request Year:** 2026  
**Department:** Facilities  
**Project Name:** Jail: Parking Lot Lights  
**Classification:** Project  
**Type:** New



**Estimated Start:** 1/1/2026                      **Estimated Completion:** 12/31/2026  
**Estimated Cost:** \$150,000

Federal Funding	State Funding	County Funding
\$0	\$0	\$150,000

**Project Description:**

Adding parking lot lights to the Union Lots. Two behind the jail and two across the street on Veeder and Albany Street.

**Justification:**

There is currently insufficient lighting and adding lights will improve and provide safer conditions.



# Schenectady County 2025 Capital Budget Request

**Request Year:** 2026

**Department:** Facilities

**Project Name:** Jail: Roof Replacement

**Classification:** Project

**Type:** New

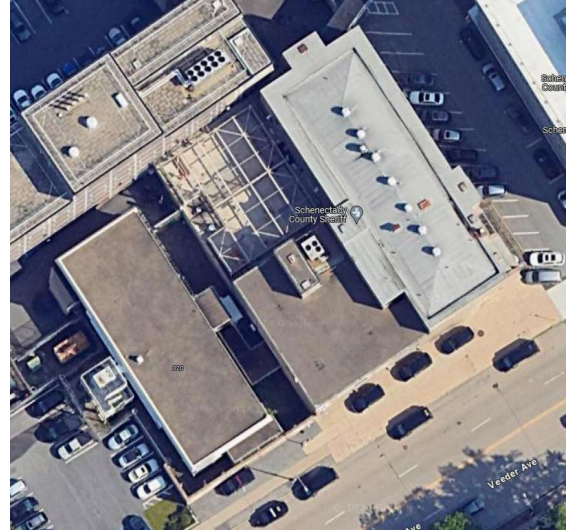

**Estimated Start:** 1/1/2026                      **Estimated Completion:** 12/31/2026

**Estimated Cost:** \$55,000

Federal Funding	State Funding	County Funding
		\$55,000

**Project Description:**

The old Jail Roof and the Dorm roofs are at the end of their useful life and need to be replaced.

**Justification:**

This project will encompass design, testing, and construction to replace these roofs.



# Schenectady County 2025 Capital Budget Request

**Request Year:** 2026

**Department:** Facilities

**Project Name:** Library: Branch Library  
Parking Lot Sealant

**Classification:** Project

**Type:** Replacement/Renewal



**Estimated Start:** 1/1/2026                      **Estimated Completion:** 12/31/2026

**Estimated Cost:** \$75,000

Federal Funding	State Funding	County Funding
\$0	\$0	\$75,000

**Project Description:**

This project is a continuation using crack fill, seal, re-striped, and coat the parking lots of all of the branch libraries.

**Justification:**

Continuation maintain parking lots, they should be crack filled, sealed, re-striped, and coated to prevent early replacement of parking lots and major patches in th future.



# Schenectady County 2025 Capital Budget Request

**Request Year:** 2026  
**Department:** Facilities  
**Project Name:** Library: Exterior Project Phase 1  
**Classification:** Project  
**Type:** New



**Estimated Start:** 1/1/2026                      **Estimated Completion:** 12/31/2026  
**Estimated Cost:** \$150,000

Federal Funding	State Funding	County Funding
\$0	\$0	\$150,000

**Project Description:**

Rotterdam - Landscaping, pressure wash building, Woodlawn - Landscaping retaining wall failing Niskayuna - pressure wash exterior, Scotia - cleanup outside, pressure wash front & back entrances.

**Justification:**

Necessary improvements for the bettering of the Library systems. At Woodlawn, the retaining wall is failing and needs to be redone.



# Schenectady County 2025 Capital Budget Request

**Request Year:** 2026

**Department:** Facilities

**Project Name:** Library: Interior Project  
Various Branches Phase 1

**Classification:** Project

**Type:** New



**Estimated Start:** 1/1/2026                      **Estimated Completion:** 12/31/2026

**Estimated Cost:** \$300,000

Federal Funding	State Funding	County Funding
\$0	\$0	\$300,000

**Project Description:**

Rotterdam - bottle filler fountain, build breakroom wall, Mont Pleasant - paint wall where divider peeled paint off and fix divider wall, Niskayuna - replace windows in reading nook both sides & breakroom windows, Refresh breakroom, Misc. - Review staff break areas for all locations, continue furniture replacement, replace water fountains with bottle fillers all locations

**Justification:**

Necessary interior improvements to better patrons and staff environment.



# Schenectady County 2025 Capital Budget Request

**Request Year:** 2026

**Department:** Facilities

**Project Name:** Library: KBJ Library 2nd Floor Design Year

**Classification:** Project

**Type:** New



**Estimated Start:** 1/1/2026

**Estimated Completion:** 12/31/2026

**Estimated Cost:** \$50,000

Federal Funding	State Funding	County Funding
\$0	\$0	\$50,000

**Project Description:**

Architect & design fees for feasibility study to rework 2nd floor.

**Justification:**

Current space is not being used to full capability. A study is needed to see what can be feasibly done.



# Schenectady County 2025 Capital Budget Request

**Request Year:** 2026

**Department:** Facilities

**Project Name:** Library: Niskayuna Branch  
Parking Lights &  
Sidewalks Phase 2



**Classification:** Project

**Type:** New

**Estimated Start:** 1/1/2026

**Estimated Completion:** 12/31/2026

**Estimated Cost:** \$130,000

Federal Funding	State Funding	County Funding
\$0	\$0	\$130,000

**Project Description:**

Replacement of damaged and unsafe sidewalks. Replacement of old pole lights in parking area for new LED.

**Justification:**

Current sidewalks are cracked, broken, and unlevel. This creates unsafe walking path. The lights are old and need to be replaced.



# Schenectady County 2025 Capital Budget Request

**Request Year:** 2026

**Department:** Schenectady County  
Community College

**Project Name:** College-wide Fire Alarm

**Classification:** Project

**Type:** Existing



**Estimated Start:** 4/1/2026                      **Estimated Completion:** 6/30/2027

**Estimated Cost:** \$1,500,000

Federal Funding	State Funding	County Funding
\$0	\$750,000	\$750,000

**Project Description:**

Replacement of the campus-wide fire alarm system

**Justification:**

The campus-wide fire alarm system is an older limited system that experiences frequent false alarms and is not integrated. A new system is needed to provide reliable fire protection and that includes a voice annunciator.





# Schenectady County 2025 Capital Budget Request

**Request Year:** 2026

**Department:** Schenectady County  
Community College

**Project Name:** Data Center Consolidation

**Classification:** Project

**Type:** Replacement/Renewal

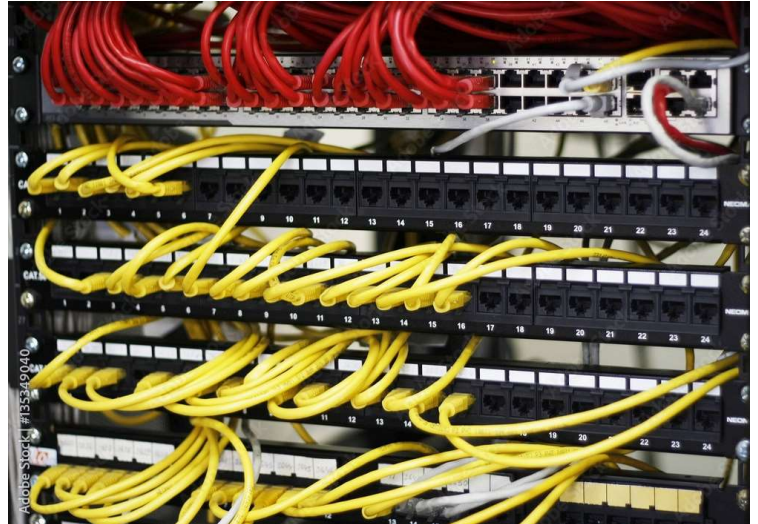

**Estimated Start:** 4/1/2026                      **Estimated Completion:** 6/30/2027

**Estimated Cost:** \$2,500,000

Federal Funding	State Funding	County Funding
\$0	\$1,250,000	\$1,250,000

**Project Description:**

Design and construction of a new IT Data Center on the 4th floor of Elston Hall.

**Justification:**

The IT Data Center will be re-designed and expanded on the 4th floor of Elston Hall. This renovation will permit better configuration of space and allow the entire ITS Department to be co-located on one floor.



# Schenectady County 2025 Capital Budget Request

**Request Year:** 2026

**Department:** Schenectady County  
Community College

**Project Name:** Daycare Center  
Playground & Quad  
Beautification

**Classification:** Project

**Type:** Replacement/Renewal



**Estimated Start:** 4/1/2026                      **Estimated Completion:** 6/30/2027

**Estimated Cost:** \$800,000

Federal Funding	State Funding	County Funding
\$0	\$400,000	\$400,000

**Project Description:**

Replacement of daycare playground equipment that is failing and unsafe for use and replacement of current paving stones and broken concrete walkways/railings in the main quad area.

**Justification:**

The daycare playground equipment is failing and no longer safe for use. Paving stones, concrete walkways and metal railings in the main quad are broken, cracked from settling or rusted due to age and in need of replacement due to safety issues.



# Schenectady County 2025 Capital Budget Request

**Request Year:** 2026

**Department:** Schenectady County  
Community College

**Project Name:** Elston Hall: Basement  
Hallway Renovation

**Classification:** Project

**Type:** Replacement/Renewal

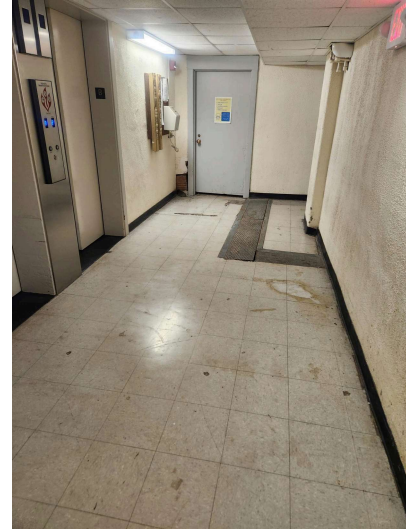

**Estimated Start:** 4/1/2026                      **Estimated Completion:** 6/30/2027

**Estimated Cost:** \$1,000,000

Federal Funding	State Funding	County Funding
\$0	\$500,000	\$500,000

**Project Description:**

Renovation of the Elston Hall basement walls, floors, ceilings and lighting. Project includes repair/replacement of a grease trap and building sewer line.

**Justification:**

The Elston Hall basement hallway is in poor condition due to age and building settling. The project includes replacement of the hallway grease trap which is in poor condition and in need of replacement. Examination and replacement of the building's main sewer line is included due to recent clog/failures. The fit and finish of this main point of egress is needed as the lighting is poor and hallway surfaces are uneven.



# Schenectady County 2025 Capital Budget Request

**Request Year:** 2026

**Department:** Schenectady County  
Community College

**Project Name:** Elston Hall: Facade &  
Window Restoration

**Classification:** Project

**Type:** Existing



**Estimated Start:** 4/1/2026 **Estimated Completion:** 6/30/2027

**Estimated Cost:** \$2,500,000

Federal Funding	State Funding	County Funding
\$0	\$1,250,000	\$1,250,000

**Project Description:**

Restoration of the North and South sides of the Elston Hall exterior to include replacement of broken stonework, replacement of the relief angle and re-pointing of brickwork. This includes restoration of the first floor historical windows.

**Justification:**

This is the second phase of a three phase project to restore the exterior of Elston Hall. During the 2023 project, contractors determined the third floor relief angle required replacement and reattachment to the building. This project will correct that issue, replace broken and cracked cast stone and restore the first floor historic windows of the building.



# Schenectady County 2025 Capital Budget Request

**Request Year:** 2026

**Department:** Schenectady County  
Community College

**Project Name:** Elston Hall: Student  
Affairs Renovation

**Classification:** Project

**Type:** Existing



**Estimated Start:** 4/1/2026                      **Estimated Completion:** 6/30/2027

**Estimated Cost:** \$4,500,000

Federal Funding	State Funding	County Funding
\$0	\$2,250,000	\$2,250,000

**Project Description:**

Restoration and refinish of the Student Affairs and Counseling area

**Justification:**

Design and renovation to the second floor of Elston Hall where the Student Affairs and Counseling offices are located. This area was constructed in the late 1960s and is in need of reconfiguration of working areas and replacement of outdated HVAC systems.



# Schenectady County 2025 Capital Budget Request

**Request Year:** 2026

**Department:** Schenectady County  
Community College

**Project Name:** Elston Hall: Testing Center  
Expansion & Renovation

**Classification:** Project

**Type:** Replacement/Renewal



**Estimated Start:** 4/1/2026                      **Estimated Completion:** 6/30/2027

**Estimated Cost:** \$1,600,000

Federal Funding	State Funding	County Funding
\$0	\$800,000	\$800,000

**Project Description:**

Expansion and renovation of the SUNY Schenectady Testing Center in Elston Hall.

**Justification:**

The existing Testing Center is located in a 950-square feet area on the 4th floor of Elston Hall. Current location does not provide adequate space for a reception area, office space or disability testing. It will be relocated to the second floor of Elston Hall.



# Schenectady County 2025 Capital Budget Request

**Request Year:** 2026

**Department:** Schenectady County  
Community College

**Project Name:** Van Curler Room  
Restoration

**Classification:** Project

**Type:** Replacement/Renewal

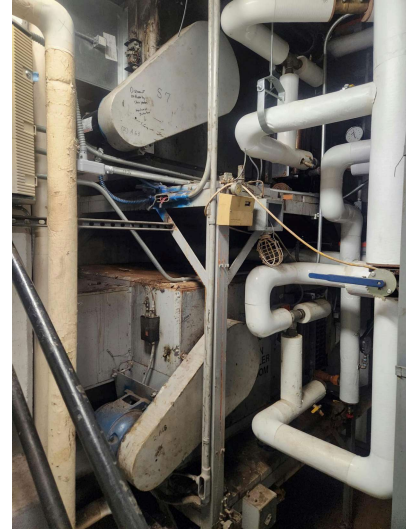

**Estimated Start:** 4/1/2026                      **Estimated Completion:** 6/30/2027

**Estimated Cost:** \$1,500,000

Federal Funding	State Funding	County Funding
\$0	\$750,000	\$750,000

**Project Description:**

Restoration and refinish of the Van Curler Ballroom and associated HVAC systems.

**Justification:**

The Van Curler Room is the college’s main culinary banquet room which is in need of renovation. The room’s fit and finish is dated with a failing center room movable wall which is in need of replacement. The room’s HVAC system requires replacement due to age and failing mechanical systems.



# Schenectady County 2025 Capital Budget Request

**Request Year:** 2026

**Department:** Unified Communication Center

**Project Name:** Countywide CAD/RMS

**Classification:** Project

**Type:** Replacement/Renewal

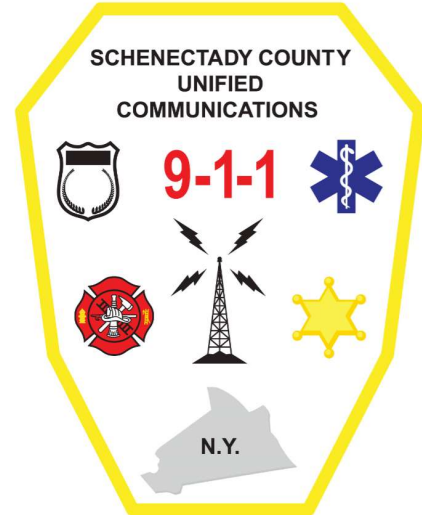

**Estimated Start:** 1/1/2026 **Estimated Completion:** 12/31/2027

**Estimated Cost:** \$1,700,000

Federal Funding	State Funding	County Funding
\$0	\$0	\$1,700,000

**Project Description:**

The 911 Center uses Pulsiam CAD/RMS to dispatch for all Police, Fire and EMS agencies in the County. This product that we use was adopted when the UCC was formed. The program that the UCC uses for CAD dispatch is called Hiterm. This product is no longer being supported and we are being forced to use what we believe is a far less user-friendly system. There are only 3 agencies left in the entire state using this software as other options have far more capabilities. We have started demos for other vendor products and see immediate benefits to making a change. There will be a costs-sharing conversation that will need to happen as the City and Towns pay for the UCC also, however the initial Capital budget will need to go through the County Process.

**Justification:**

Our current product is no longer being supported so a change is needed. The intent here is to adopt one standardized CAD/RMS for the entire County to use. New systems are far more user-friendly which will cut down the lengthy training process for new hire dispatchers, provide immediate officer safety information that our current system does not, and standardize the county for information sharing purposes.





# Schenectady County 2025 Capital Budget Request

**Request Year:** 2026

**Department:** Aviation

**Project Name:** Mini-Split Replacement for Tower Cab

**Classification:** Equipment

**Type:** New



**Estimated Start:** 5/1/2026

**Estimated Completion:** 6/30/2026

**Estimated Cost:** \$70,000

Federal Funding	State Funding	County Funding
\$0	\$0	\$70,000

**Project Description:**

The project involves the replacement the two existing mini-split air conditioning system for the airport tower cab. The work will require the removal of the existing air handlers and the compressor / condenser and replacing with new equipment.

**Justification:**

The existing equipment, now over 15 years old, has become unreliable and requires ongoing maintenance to keep it operational. The tower cab, with 6-foot-tall windows around its entire perimeter, experiences significant temperature increases during the summer. Despite insulation and window upgrades since its construction in the 1950s, the heat gain remains substantial. Air conditioning units are essential to maintain a comfortable environment and ensure the proper functioning of electronic equipment.



# Schenectady County 2025 Capital Budget Request

**Request Year:** 2026  
**Department:** Glendale Nursing Home  
**Project Name:** Nurse Call Bell System  
Phase 3  
**Classification:** Equipment  
**Type:** Replacement/Renewal

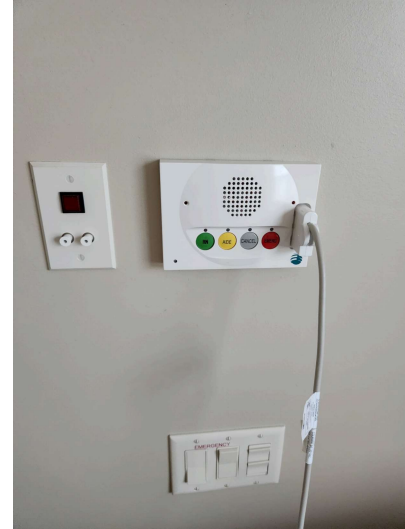

**Estimated Start:** 1/1/2026                      **Estimated Completion:** 12/31/2026  
**Estimated Cost:** \$50,750

Federal Funding	State Funding	County Funding
\$0	\$0	\$50,750

**Project Description:**

Replacement of the Nurse Call Bell System for one unit

**Justification:**

To replace aging Nurse Call System. The parts for our current system have been discontinued. This will be a phased project to replace one unit per year.



# Schenectady County 2025 Capital Budget Request

**Request Year:** 2026

**Department:** Schenectady County  
Community College

**Project Name:** Classroom Furniture  
Replacement

**Classification:** Equipment

**Type:** Replacement/Renewal



**Estimated Start:** 4/1/2026                      **Estimated Completion:** 12/31/2026

**Estimated Cost:** \$250,000

Federal Funding	State Funding	County Funding
\$0	\$125,000	\$125,000

**Project Description:**  
Replacement of classroom furniture

**Justification:**  
Replacement of worn and used classroom furniture needed by students to attend class.



# Schenectady County 2025 Capital Budget Request

**Request Year:** 2026

**Department:** Schenectady County  
Community College

**Project Name:** Classroom Furniture  
Replacement

**Classification:** Equipment

**Type:** Replacement/Renewal

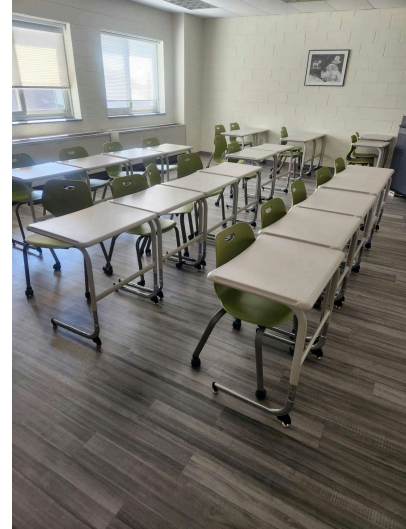

**Estimated Start:** 4/1/2026                      **Estimated Completion:** 6/30/2026

**Estimated Cost:** \$500,000

Federal Funding	State Funding	County Funding
\$0	\$250,000	\$250,000

**Project Description:**

Replacement of outdated and non-ADA compliant classroom furniture.

**Justification:**

Main campus classroom furniture requires replacement due to wear and age. Current furniture is dated and, in some instances, not ADA compliant.



# Schenectady County 2025 Capital Budget Request

**Request Year:** 2026

**Department:** Sheriff - All Divisions

**Project Name:** Sheriff Dept.: Vehicle Replacements and Upfitting

**Classification:** Equipment

**Type:** New



**Estimated Start:** 1/1/2026                      **Estimated Completion:** 12/31/2026

**Estimated Cost:** \$250,000

Federal Funding	State Funding	County Funding
\$0	\$0	\$250,000

### Project Description:

The Department of Engineering and Public Works manages the Sheriff's Department's fleet and recommends when replacement of vehicles is necessary. For 2026, the Sheriff's request is for:  
-Three (3) Patrol Interceptors with upfitting. Upfitting will include Panasonic Toughbook laptops and docking stations.

### Justification:

Ongoing replacement of the Sheriff Patrol vehicles is necessary due to the annual mileage and associated wear and tear on the vehicles.



# Schenectady County 2025 Capital Budget Request

**Request Year:** 2027

**Department:** Schenectady County  
Community College

**Project Name:** Elston Hall: Facade Phase  
5

**Classification:** Project

**Type:** New



**Estimated Start:** 1/1/2026                      **Estimated Completion:** 12/31/2026

**Estimated Cost:** \$1,000,000

Federal Funding	State Funding	County Funding
\$0	\$500,000	\$500,000

**Project Description:**

Continuous restoration of the Elston Hall Facade and other exterior work.

**Justification:**

Bricks, windows, cast stone, and other replacements needed due to disrepair.



# Schenectady County 2025 Capital Budget Request

**Request Year:** 2027

**Department:** Glendale Nursing Home

**Project Name:** Nurse Call Bell System  
Phase 4

**Classification:** Equipment

**Type:** Replacement/Renewal



**Estimated Start:** 1/1/2027                      **Estimated Completion:** 12/31/2027

**Estimated Cost:** \$50,750

Federal Funding	State Funding	County Funding
\$0	\$0	\$50,750

**Project Description:**

Replacement of the Nurse Call Bell System for one unit

**Justification:**

To replace aging Nurse Call System. The parts for our current system have been discontinued. This will be a phased project to replace one unit per year.



# Schenectady County 2025 Capital Budget Request

**Request Year:** 2027

**Department:** Schenectady County  
Compost & Recycling  
Facility

**Project Name:** Compost Facility Front  
End Loader

**Classification:** Equipment

**Type:** Replacement/Renewal



**Estimated Start:** 1/1/2027

**Estimated Completion:** 12/31/2027

**Estimated Cost:** \$343,000

Federal Funding	State Funding	County Funding
\$0	\$171,500	\$171,500

**Project Description:**

The Schenectady County Compost Facility accepted more than 20,000 cubic yards of yard-waste annually. This material needs to be processed into compost and wood mulch before being sold to the public. In order to move and process this material, the Front End Loaders are needed.

**Justification:**

The Hyundai Front End Loader, that will be replaced with new loader, was purchased in 2013. It has been in use since and now has 12,100 hours on the engine and drivetrain. This machine is crucial to the success of the Compost Facility and although it is running strong today, replacement will be necessary in a few years.





# Schenectady County 2025 Capital Budget Request

**Request Year:** 2027

**Department:** Sheriff - All Divisions

**Project Name:** Sheriff Dept.: Vehicle Replacements and Upfitting

**Classification:** Equipment

**Type:** New



**Estimated Start:** 1/1/2027                                              **Estimated Completion:** 12/31/2027

**Estimated Cost:** \$250,000

Federal Funding	State Funding	County Funding
\$0	\$0	\$250,000

**Project Description:**

The Department of Engineering and Public Works manages the Sheriff's Department's fleet and recommends when replacement of vehicles is necessary. For 2027, the Sheriff's request is for:  
 -Three (3) Patrol Interceptors with upfitting. Upfitting will include Panasonic Toughbook laptops and docking stations.

**Justification:**

Ongoing replacement of the Sheriff Patrol vehicles is necessary due to the annual mileage and associated wear and tear on the vehicles.



# Schenectady County 2025 Capital Budget Request

**Request Year:** 2028

**Department:** Facilities

**Project Name:** Library: KBJ Library  
Multistack Chiller Controls

**Classification:** Project

**Type:** New



**Estimated Start:** 1/1/2028                      **Estimated Completion:** 12/31/2028

**Estimated Cost:** \$100,000

Federal Funding	State Funding	County Funding
\$0	\$0	\$100,000

**Project Description:**

Replace multi-stack chiller controls and pot feeder at Karen B. Johnson Library.

**Justification:**

The current control system is at the end of its useful life and we cannot easily get parts. As KBJ is a cooling station during the summer, we cannot afford for this to go down. We need to replace this and a pot feeder at the KBJ.



# Schenectady County 2025 Capital Budget Request

**Request Year:** 2028

**Department:** Glendale Nursing Home

**Project Name:** Nurse Call Bell System  
Phase 5

**Classification:** Equipment

**Type:** Replacement/Renewal

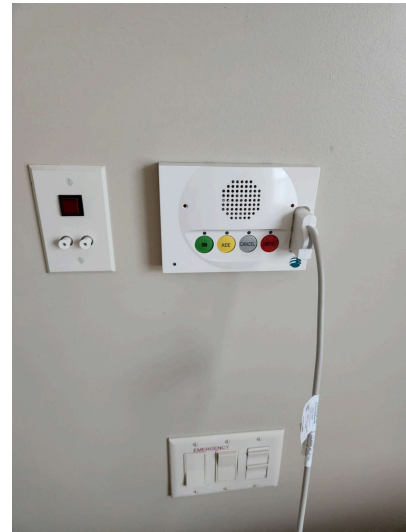

**Estimated Start:** 1/1/2028                      **Estimated Completion:** 12/31/2028

**Estimated Cost:** \$50,750

Federal Funding	State Funding	County Funding
\$0	\$0	\$50,750

**Project Description:**

Replacement of the Nurse Call Bell System for one unit.

**Justification:**

To replace aging Nurse Call System. The parts for our current system have been discontinued. This will be a phased project to replace one unit per year.



# Schenectady County 2025 Capital Budget Request

**Request Year:** 2028

**Department:** Sheriff - All Divisions

**Project Name:** Sheriff Dept.: Vehicle Replacements and Upfitting

**Classification:** Equipment

**Type:** New



**Estimated Start:** 1/1/2028                      **Estimated Completion:** 12/31/2028

**Estimated Cost:** \$250,000

Federal Funding	State Funding	County Funding
\$0	\$0	\$250,000

**Project Description:**

The Department of Engineering and Public Works manages the Sheriff's Department's fleet and recommends when replacement of vehicles is necessary. For 2028, the Sheriff's request is for:  
 -Three (3) Patrol Interceptors with upfitting. Upfitting will include Panasonic Toughbook laptops and docking stations.

**Justification:**

Ongoing replacement of the Sheriff Patrol vehicles is necessary due to the annual mileage and associated wear and tear on the vehicles.



# Schenectady County 2025 Capital Budget Request

**Request Year:** 2029

**Department:** Engineering and Public Works

**Project Name:** Emergency Management Office: 2025 Mobile Command Post Vehicle

**Classification:** Equipment

**Type:** Replacement/Renewal



**Estimated Start:** 1/1/2028                      **Estimated Completion:** 12/31/2028

**Estimated Cost:** \$1,500,000

Federal Funding	State Funding	County Funding
\$0	\$0	\$1,500,000

**Project Description:**

New 2025 Mobile Command Post Vehicle for Emergency Management Department

**Justification:**

This unit will replace 3311, a mobile command post C-100 which is a 2003 Miranda mobile home that has been semi converted to a command post configuration. It is in very poor condition with numerous issues. This vehicle is used to support major functions throughout the County along with UCC emergencies.



# Schenectady County 2025 Capital Budget Request

**Request Year:** 2029

**Department:** Sheriff - All Divisions

**Project Name:** Sheriff Dept.: Vehicle Replacements and Upfitting

**Classification:** Equipment

**Type:** New



**Estimated Start:** 1/1/2029                      **Estimated Completion:** 12/31/2029

**Estimated Cost:** \$250,000

Federal Funding	State Funding	County Funding
\$0	\$0	\$250,000

**Project Description:**

The Department of Engineering and Public Works manages the Sheriff's Department's fleet and recommends when replacement of vehicles is necessary. For 2029, the Sheriff's request is for:  
 -Three (3) Patrol Interceptors with upfitting. Upfitting will include Panasonic Toughbook laptops and docking stations.

**Justification:**

Ongoing replacement of the Sheriff Patrol vehicles is necessary due to the annual mileage and associated wear and tear on the vehicles.



# Schenectady County 2025 Capital Budget Request

**Request Year:** 2030

**Department:** Sheriff - All Divisions

**Project Name:** Sheriff Dept.: Vehicle Replacements and Upfitting

**Classification:** Equipment

**Type:** New



**Estimated Start:** 1/1/2030                      **Estimated Completion:** 12/31/2030

**Estimated Cost:** \$250,000

Federal Funding	State Funding	County Funding
\$0	\$0	\$250,000

**Project Description:**

The Department of Engineering and Public Works manages the Sheriff's Department's fleet and recommends when replacement of vehicles is necessary. For 2030, the Sheriff's request is for:  
 -Three (3) Patrol Interceptors with upfitting. Upfitting will include Panasonic Toughbook laptops and docking stations.

**Justification:**

Ongoing replacement of the Sheriff Patrol vehicles is necessary due to the annual mileage and associated wear and tear on the vehicles.