

SCHENECTADY COUNTY
NEW YORK



TENTATIVE
2025-2030
CAPITAL IMPROVEMENT
PROGRAM

TABLE OF CONTENTS

<u>CAPITAL PROGRAM SUMMARY CHARTS</u>	<u>PAGE NO.</u>
1. RECOMMENDED CAPITAL PROJECTS FOR 2025	1
2. RECOMMENDED CAPITAL EQUIPMENT FOR 2025	2
3. RECOMMENDED CAPITAL BUDGET DETAIL 2025 - 2030	3
4. RECOMMENDED VEHICLE PURCHASE LIST 2025	6
<u>CAPITAL PROJECT REQUESTS, DETAILED INFORMATION</u>	8
1. AVIATION	9
2. CIVIL SERVICE/HUMAN RESOURCES	11
3. ENGINEERING AND PUBLIC WORKS	12
4. FACILITIES	14
5. GLENDALE NURSING HOME	34
6. INFORMATION SERVICES	35
7. SCHENECTADY COUNTY COMMUNITY COLLEGE	36
<u>CAPITAL EQUIPMENT REQUESTS, DETAILED INFORMATION</u>	40
1. BOARD OF ELECTIONS	41
2. ENGINEERING AND PUBLIC WORKS	42
3. GLENDALE NURSING HOME	54
4. INFORMATION SERVICES	56
5. PURCHASING	58
6. SHERIFF	59
<u>FUTURE CAPITAL PLAN REQUESTS 2026-2030</u>	61

2025
RECOMMENDED CAPITAL PROJECTS & EQUIPMENT

Dept./Page No.	Project Number	COUNTY APPROPRIATIONS		REIMBURSEMENTS		TOTAL
		OPERATING	SERIAL BONDS	STATE	FEDERAL	
TOTAL CAPITAL REQUESTS-YEAR 2025: PROJECTS		\$ 1,010,000	\$ 10,290,650	\$ 5,076,000	\$ 6,092,350	\$ 22,469,000
<u>Aviation</u>						
9	General Aviation North Apron Reconstruction (Construction/Inspection)	H5610250001	\$ 320,650		\$ 6,092,350	\$ 6,413,000
10	Storage Building for Airport Equipment	H1620250002	\$ 1,100,000			\$ 1,100,000
<u>Civil Service/Human Resources</u>						
11	Human Resources Software-Onboarding & Application	H1430250003	\$ 100,000			\$ 100,000
<u>Engineering and Public Works</u>						
12	County Highway Improvements/County-Wide Highway System	H5110250004	\$ 2,000,000	\$ 3,376,000		\$ 5,376,000
13	DEPW: Rehabilitation of Recycling Building	H5110250005	\$ 500,000			\$ 500,000
<u>Facilities</u>						
14	797 Broadway: Building Upgrades Phase 2	H1620250006	\$ 1,635,000			\$ 1,635,000
15	797 Broadway: HVAC Controls Change Out	H1620250007	\$ 300,000			\$ 300,000
16	Aviation: Roof Replacement Project at the Airport Tower	H1620250008	\$ 250,000			\$ 250,000
17	Business Center: Fire Alarm Replacement	H1620250009	\$ 100,000			\$ 100,000
18	Courthouse & COB Fire System Separation Design Year	H1620250010	\$ 70,000			\$ 70,000
19	Courthouse Basement Area & Mechanical Room Phase 3	H1620250011	\$ 300,000			\$ 300,000
20	Courthouse: Boiler Room Project	H1620250012	\$ 300,000			\$ 300,000
21	Jail: Build Shed w/ Lighting for Storage in Blue Lot	H1620250014	\$ 15,000			\$ 15,000
22	Jail: Cell Night Lights	H1620250015	\$ 300,000			\$ 300,000
23	Jail: Dorm Windows Replacement	H1620250016	\$ 500,000			\$ 500,000
24	Jail: Drains and Penthouse	H1620250017	\$ 50,000			\$ 50,000
25	Jail: Fires Sprinkler Head Change Out	H1620250018	\$ 75,000			\$ 75,000
26	Jail: Flush Valves Phase 2	H1620250019	\$ 500,000			\$ 500,000
27	Jail: Repair Brick w/ Stainless Steel Guard Exterior Visitor Area	H1620250020	\$ 30,000			\$ 30,000
28	Jail: Sally Port W1 Gate Demolition & Replacement	H1620250021	\$ 125,000			\$ 125,000
29	Library: Bookdrops Project	H1620250022	\$ 50,000			\$ 50,000
30	Library: Fire Panels Phase 2	H1620250023	\$ 200,000			\$ 200,000
31	Library: Signage Project Phase 1	H1620250024	\$ 60,000			\$ 60,000
32	Library: Woodlawn Library Feasibility Study for Quaker & Woodlawn Expansion	H1620250025	\$ 75,000			\$ 75,000
33	Unified Communication Center: HVAC upgrade Phase 1	H1620250026	\$ 75,000			\$ 75,000
<u>Glendale Nursing Home</u>						
34	Glendale: Garage	B1620250027	\$ 500,000			\$ 500,000
<u>Information Services</u>						
35	IT Security Tools	H1621250028	\$ 70,000			\$ 70,000
<u>Schenectady County Community College</u>						
36	Begley Basement Renovation	H2401250029	\$ 750,000	\$ 750,000		\$ 1,500,000
37	Culinary Program Kitchen Ventilation & Dining Room Renovation	H2401250030	\$ 300,000	\$ 300,000		\$ 600,000
38	Elston Hall: Gathering Area and Kitchen Renovation	H2401250031	\$ 625,000	\$ 625,000		\$ 1,250,000
39	Mechanical, Electrical, and Plumbing Study	H2401250032	\$ 25,000	\$ 25,000		\$ 50,000

2025
RECOMMENDED CAPITAL PROJECTS & EQUIPMENT

Dept./Page No.	Project Number	COUNTY APPROPRIATIONS		REIMBURSEMENTS		TOTAL	
		OPERATING	SERIAL BONDS	STATE	FEDERAL		
TOTAL CAPITAL REQUESTS-YEAR 2025: EQUIPMENT		\$ 1,273,750	\$ 2,515,000			\$ 3,788,750	
<u>Board of Elections</u>							
41	New Voting Machines	H1450250033		\$ 1,000,000		\$ 1,000,000	
<u>Engineering and Public Works</u>							
42	DEPW: Refurbish Equipment	H5130250034	\$ 100,000			\$ 100,000	
43	Equipment Replacement: New TCX 635 PHD Large Truck Tire Changer	H5130250035	\$ 47,000			\$ 47,000	
44	Equipment: New 2025 Guardrail Post Pounder, GRT Utilicorp	H5130250036		\$ 255,000		\$ 255,000	
45	Equipment: Two (2) New Trailers: Facilites & DEPW	H5130250037	\$ 26,000			\$ 26,000	
46	Fleet Replacement: General County Inventory	H5130250038	\$ 395,000			\$ 395,000	
47	Fleet Replacement: MV 607 SBA 4x2 Crew Truck with Dump Body	H5130250039		\$ 145,000		\$ 145,000	
48	Fleet Replacement: New 2025 DD25B Volvo Asphalt Roller	H5130250040	\$ 52,000			\$ 52,000	
49	Fleet Replacement: New 2025 HV507 SFA Single Axle Dump Truck	H5130250041		\$ 275,000		\$ 275,000	
50	Fleet Replacement: New 2025 HX520 SFA Tandem Dump Truck	H5130250042		\$ 330,000		\$ 330,000	
51	Fleet Replacement: New 2025 International Dump Truck 6x6	H5130250043		\$ 300,000		\$ 300,000	
52	Fleet Replacement: New 2025 T66 T4 Bobcat Compact Track Loader	H5130250044		\$ 78,000		\$ 78,000	
53	Fleet Replacement: New 2025 Volvo ECR88D Excavator	H5130250045		\$ 132,000		\$ 132,000	
<u>Glendale Nursing Home</u>							
54	Fleet Replacement: Glendale 2025 2500 Chevy or Ford F-250	B6031250046	\$ 59,000			\$ 59,000	
55	Nurse Call Bell System for 1 Unit	B6031250047	\$ 50,750			\$ 50,750	
<u>Information Services</u>							
56	Network Switch Upgrade	H1621250048	\$ 100,000			\$ 100,000	
57	Network Test Equipment	H1621250049	\$ 45,000			\$ 45,000	
<u>Purchasing</u>							
58	Copiers and Equipment	H1345250050	\$ 30,000			\$ 30,000	
<u>Sheriff - All Divisions</u>							
59	Sheriff Dept.: 2025 Ford Explorer for Task Force Unit	H3160250051	\$ 65,000			\$ 65,000	
60	Sheriff Dept.: Vehicle Replacements and Upfitting	H3110250052	\$ 304,000			\$ 304,000	
TOTAL CAPITAL -YEAR 2025: PROJECTS & EQUIPMENT			\$ 2,283,750	\$ 12,805,650	\$ 5,076,000	\$ 6,092,350	\$ 26,257,750

**5 YEAR RECOMMENDED CAPITAL BUDGET
2025-2030**

	2025	2026	2027	2028	2029	2030	Grand Total
Aviation	\$ 7,513,000.00	\$ 70,000.00					\$ 7,583,000.00
General Aviation North Apron Reconstruction (Construction/Inspection)	\$ 6,413,000.00						\$ 6,413,000.00
Mini-Split Replacement for Tower Cab		\$ 70,000.00					\$ 70,000.00
Storage Building for Airport Equipment	\$ 1,100,000.00						\$ 1,100,000.00
Board of Elections	\$ 1,000,000.00						\$ 1,000,000.00
New Voting Machines	\$ 1,000,000.00						\$ 1,000,000.00
Civil Service/Human Resources	\$ 100,000.00						\$ 100,000.00
Human Resources Software-Onboarding & Application	\$ 100,000.00						\$ 100,000.00
Engineering and Public Works	\$ 8,011,000.00				\$ 1,500,000.00		\$ 9,511,000.00
Emergency Management Office: 2025 Mobile Command Post Vehicle					\$ 1,500,000.00		\$ 1,500,000.00
County Highway Improvements/County-Wide Highway System	\$ 5,376,000.00						\$ 5,376,000.00
DEPW: Refurbish Equipment	\$ 100,000.00						\$ 100,000.00
DEPW: Rehabilitation of Recycling Building	\$ 500,000.00						\$ 500,000.00
Equipment Replacement: New TCX 635 PHD Large Truck Tire Changer	\$ 47,000.00						\$ 47,000.00
Equipment: New 2025 Guardrail Post Pounder, GRT Utilicorp	\$ 255,000.00						\$ 255,000.00
Equipment: Two (2) New Trailers: Facilites & DEPW	\$ 26,000.00						\$ 26,000.00
Fleet Replacement: General County Inventory	\$ 395,000.00						\$ 395,000.00
Fleet Replacement: MV 607 SBA 4x2 Crew Truck with Dump Body	\$ 145,000.00						\$ 145,000.00
Fleet Replacement: New 2025 DD25B Volvo Asphalt Roller	\$ 52,000.00						\$ 52,000.00
Fleet Replacement: New 2025 HV507 SFA Single Axle Dump Truck	\$ 275,000.00						\$ 275,000.00
Fleet Replacement: New 2025 HX520 SFA Tandem Dump Truck	\$ 330,000.00						\$ 330,000.00
Fleet Replacement: New 2025 International Dump Truck 6x6	\$ 300,000.00						\$ 300,000.00
Fleet Replacement: New 2025 T66 T4 Bobcat Compact Track Loader	\$ 78,000.00						\$ 78,000.00
Fleet Replacement: New 2025 Volvo ECR88D Excavator	\$ 132,000.00						\$ 132,000.00
Facilities	\$ 5,010,000.00	\$ 11,630,000.00		\$ 100,000.00			\$ 16,740,000.00
797 Broadway: Building Upgrades Phase 2	\$ 1,635,000.00						\$ 1,635,000.00
797 Broadway: HVAC Controls Change Out	\$ 300,000.00						\$ 300,000.00
Aviation: Roof Replacement Project at the Airport Tower	\$ 250,000.00						\$ 250,000.00
Business Center: Exterior Rehabilitation		\$ 150,000.00					\$ 150,000.00
Business Center: Fire Alarm Replacement	\$ 100,000.00						\$ 100,000.00
Business Center: Interior Upgrades		\$ 30,000.00					\$ 30,000.00
County Office Building: Streetscape Phase 2 (Courthouse & 608 State)		\$ 750,000.00					\$ 750,000.00
Courthouse & COB Fire System Separation Design Year	\$ 70,000.00						\$ 70,000.00
Courthouse Basement Area & Mechanical Room Phase 3	\$ 300,000.00						\$ 300,000.00
Courthouse Exterior Masonry		\$ 1,000,000.00					\$ 1,000,000.00
Courthouse Facade Renovation		\$ 1,000,000.00					\$ 1,000,000.00
Courthouse Lobby refresh PH1 & Reimagine Historic		\$ 1,500,000.00					\$ 1,500,000.00
Courthouse: Bathroom Renovation Phase 2		\$ 500,000.00					\$ 500,000.00
Courthouse: Boiler Room Project	\$ 300,000.00						\$ 300,000.00
Courthouse: Electrical Panel Upgrades		\$ 750,000.00					\$ 750,000.00
Courthouse: Exterior Rehabilitation		\$ 750,000.00					\$ 750,000.00
DEPW: Roof Replacement Barrel Vault Roof		\$ 1,500,000.00					\$ 1,500,000.00
Jail: Booking Area Refresh		\$ 400,000.00					\$ 400,000.00
Jail: Build Shed w/ Lighting for Storage in Blue Lot	\$ 15,000.00						\$ 15,000.00
Jail: Cell Night Lights	\$ 300,000.00						\$ 300,000.00
Jail: Dorm Hallway Refresh		\$ 150,000.00					\$ 150,000.00
Jail: Dorm Windows Replacement	\$ 500,000.00						\$ 500,000.00
Jail: Drains and Penthouse	\$ 50,000.00						\$ 50,000.00

**5 YEAR RECOMMENDED CAPITAL BUDGET
2025-2030**

	2025	2026	2027	2028	2029	2030	Grand Total
Jail: Epoxy Floors 1-4 Phase 3		\$ 500,000.00					\$ 500,000.00
Jail: Exterior Phase 3		\$ 175,000.00					\$ 175,000.00
Jail: Fires Sprinkler Head Change Out	\$ 75,000.00						\$ 75,000.00
Jail: Flush Valves Phase 2	\$ 500,000.00						\$ 500,000.00
Jail: In Depth Design Study of the Jail		\$ 65,000.00					\$ 65,000.00
Jail: Locker Room and Administrative Area Refresh		\$ 750,000.00					\$ 750,000.00
Jail: Locker Room Phase 2 and Administration Area		\$ 750,000.00					\$ 750,000.00
Jail: Parking Lot Lights		\$ 150,000.00					\$ 150,000.00
Jail: Repair Brick w/ Stainless Steel Guard Exterior Visitor Area	\$ 30,000.00						\$ 30,000.00
Jail: Roof Replacement		\$ 55,000.00					\$ 55,000.00
Jail: Sally Port W1 Gate Demolition & Replacement	\$ 125,000.00						\$ 125,000.00
Library: Bookdrops Project	\$ 50,000.00						\$ 50,000.00
Library: Branch Library Parking Lot Sealant		\$ 75,000.00					\$ 75,000.00
Library: Exterior Project Phase 1		\$ 150,000.00					\$ 150,000.00
Library: Fire Panels Phase 2	\$ 200,000.00						\$ 200,000.00
Library: Interior Project Various Branches Phase 1		\$ 300,000.00					\$ 300,000.00
Library: KBJ Library 2nd Floor Design Year		\$ 50,000.00					\$ 50,000.00
Library: KBJ Library Multistack Chiller Controls				\$ 100,000.00			\$ 100,000.00
Library: Niskayuna Branch Parking Lights & Sidewalks Phase 2		\$ 130,000.00					\$ 130,000.00
Library: Signage Project Phase 1	\$ 60,000.00						\$ 60,000.00
Library: Woodlawn Library Feasibility Study for Quaker & Woodlawn Expansion	\$ 75,000.00						\$ 75,000.00
Unified Communication Center: HVAC upgrade Phase 1	\$ 75,000.00						\$ 75,000.00
Glendale Nursing Home	\$ 609,750.00	\$ 50,750.00	\$ 50,750.00	\$ 50,750.00			\$ 762,000.00
Fleet Replacement: Glendale 2025 2500 Chevy or Ford F-250	\$ 59,000.00						\$ 59,000.00
Glendale: Garage	\$ 500,000.00						\$ 500,000.00
Nurse Call Bell System for 1 Unit	\$ 50,750.00						\$ 50,750.00
Nurse Call Bell System Phase 3		\$ 50,750.00					\$ 50,750.00
Nurse Call Bell System Phase 4			\$ 50,750.00				\$ 50,750.00
Nurse Call Bell System Phase 5				\$ 50,750.00			\$ 50,750.00
Information Services	\$ 215,000.00						\$ 215,000.00
IT Security Tools	\$ 70,000.00						\$ 70,000.00
Network Switch Upgrade	\$ 100,000.00						\$ 100,000.00
Network Test Equipment	\$ 45,000.00						\$ 45,000.00
Purchasing	\$ 30,000.00						\$ 30,000.00
Copiers and Equipment	\$ 30,000.00						\$ 30,000.00
Schenectady County Community College	\$ 3,400,000.00	\$ 16,650,000.00	\$ 1,000,000.00				\$ 21,050,000.00
Begley Basement Renovation	\$ 1,500,000.00						\$ 1,500,000.00
Classroom Furniture Replacement		\$ 750,000.00					\$ 750,000.00
College-wide Fire Alarm		\$ 1,500,000.00					\$ 1,500,000.00
Culinary Program Kitchen Ventilation & Dining Room Renovation	\$ 600,000.00						\$ 600,000.00
Data Center Consolidation		\$ 2,500,000.00					\$ 2,500,000.00
Daycare Center Playground & Quad Beautification		\$ 800,000.00					\$ 800,000.00
Elston Hall: Basement Hallway Renovation		\$ 1,000,000.00					\$ 1,000,000.00
Elston Hall: Facade & Window Restoration		\$ 2,500,000.00					\$ 2,500,000.00
Elston Hall: Facade Phase 5			\$ 1,000,000.00				\$ 1,000,000.00
Elston Hall: Gathering Area and Kitchen Renovation	\$ 1,250,000.00						\$ 1,250,000.00
Elston Hall: Student Affairs Renovation		\$ 4,500,000.00					\$ 4,500,000.00
Elston Hall: Testing Center Expansion & Renovation		\$ 1,600,000.00					\$ 1,600,000.00
Mechanical, Electrical, and Plumbing Study	\$ 50,000.00						\$ 50,000.00

**5 YEAR RECOMMENDED CAPITAL BUDGET
2025-2030**

	2025	2026	2027	2028	2029	2030	Grand Total
Van Curler Room Restoration		\$ 1,500,000.00					\$ 1,500,000.00
Schenectady County Compost & Recycling Facility			\$ 343,000.00				\$ 343,000.00
Compost Facility Front End Loader			\$ 343,000.00				\$ 343,000.00
Sheriff - All Divisions	\$ 369,000.00	\$ 250,000.00	\$ 250,000.00	\$ 250,000.00	\$ 250,000.00	\$ 250,000.00	\$ 1,619,000.00
Sheriff Dept.: 2025 Ford Explorer for Task Force Unit	\$ 65,000.00						\$ 65,000.00
Sheriff Dept.: Vehicle Replacements and Upfitting	\$ 304,000.00	\$ 250,000.00	\$ 250,000.00	\$ 250,000.00	\$ 250,000.00	\$ 250,000.00	\$ 1,554,000.00
Unified Communication Center		\$ 1,700,000.00					\$ 1,700,000.00
Countywide CAD/RMS		\$ 1,700,000.00					\$ 1,700,000.00
TOTAL CAPITAL PROJECT REQUESTS- YEAR 2025-2030	\$ 26,257,750.00	\$ 30,350,750.00	\$ 1,643,750.00	\$ 400,750.00	\$ 1,750,000.00	\$ 250,000.00	\$ 60,653,000.00

**VEHICLE FLEET REPLACEMENT
2025 CAPITAL BUDGET**

New Vehicle Requested			Vehicle to be Replaced			
VEHICLE REPLACEMENTS:						
<u>Vehicle Type</u>	<u>Dept</u>	<u>Cost</u>	<u>Vehicle #</u>	<u>Year</u>	<u>Description</u>	<u>Justification</u>
New Chevy Colorado regular cab with toolbox and standard features	DEPW	\$49,000	1022	2010	Chevy Colorado	1002 will have approximately 88,000 miles at time of replacement. It is very rusted will go to auction frame has rust holes
New Chevy 2500 pickup extended cab with 8 foot box with standard features	DEPW	\$57,000	1011	2018	Chevy Pickup	This unit will replace 1011 a 2018 Chevy pickup for the parts department which will have approximately 150,000 miles at the time of replacement. 1011 will replace 1324 which has 183,000 miles and will go to auction
2025 Rack truck 5500 with tool box and running boards	DEPW	\$95,000	1104	2014	Rack Truck	This unit will replace 1104 which is 10 years old with 90,000 miles at the time of replacement
New 2025 Chevy Malibu with standard features	DA	\$28,000	3109	2014	Ford Fusion	This unit will replace 3109 a 2014 Ford Fusion, 3109 will replace 1014 a 2012 Ford Fusion which will have approximately 120,000 miles at the time of replacement and will go to auction
New 2025 Chevy Malibu with standard features	DA	\$28,000	3108	2014	Ford Fusion	This unit will replace 3108 a 2014 Ford Fusion, 3108 will replace 1013 a 2012 Ford Fusion which will have approximately 115,000 miles at the time of replacement and will go to auction
New Chevy Malibu with standard features	DSS	\$28,000	2179	2014	Ford Fusion	This unit will replace 2179 a 2014 Ford Fusion with approximately 108,000 miles at the time of replacement, this vehicle is 11 years old and will go to auction
New 2025 Ford Explorer With standard equipment and emergency lights	Emergency Management	\$55,000	3322	2013	Ford Fusion	This unit will replace 3322 a 2013 Ford Explorer which will have approximately 128,000 miles at the time of replacement and will go to auction
2025 Chrysler Pacifica Hybrid with standard features	Purchasing	\$55,000	4101	2014	Chevy Express	This unit will replace 4101, a 10 year old 15 passenger Chevy Express van previously used by the Sheriff's Dept. to transport prisoners. It will have approx. 127,000 miles on it at the time of replacement and starting to rust. The vehicle is not good in the snow or ice, and is too big for most of his assigned tasks. 4101 will go to auction.
GRAND TOTAL 2025 VEHICLE REPLACEMENTS :		\$395,000				

**VEHICLE FLEET REPLACEMENT
2025 CAPITAL BUDGET**

TASK FORCE

<u>New Vehicle Requested</u>			<u>Vehicle to be Replaced</u>			
<u>VEHICLE REPLACEMENTS:</u>	<u>(Listed Separately on Capital Budget)</u>					
<u>Vehicle Type</u>	<u>Dept</u>	<u>Cost</u>	<u>Vehicle #</u>	<u>Year</u>	<u>Description</u>	<u>Justification</u>
2025 Ford Explorer with standard features with emergency lights	Task Force	\$65,000				New vehicle request
GRAND TOTAL 2025 VEHICLE REPLACEMENTS :		\$65,000				

SHERIFF

<u>New Vehicle Requested</u>			<u>Vehicle to be Replaced</u>			
<u>VEHICLE REPLACEMENTS:</u>	<u>(Listed Separately on Capital Budget)</u>					
<u>Vehicle Type</u>	<u>Dept</u>	<u>Cost</u>	<u>Vehicle #</u>	<u>Year</u>	<u>Description</u>	<u>Justification</u>
Ford Interceptors (3) with Upfitting	Sheriff	\$249,000	various		Ford Interceptors	\$83,000 each. These may replace 2389 and 2360
Chevy 3500 Express Van with standard options and police features for the Jail	Sheriff	\$55,000	2378	2017	Chevy Express Van	This unit will replace 2378, which will have approx. 150,000 miles at time of replacement. 2378 will replace 3612, a 2005 Chevy Express Van that will go to auction.
GRAND TOTAL 2025 VEHICLE REPLACEMENTS :		\$304,000				

CAPITAL PROJECT REQUESTS 2025



Schenectady County 2025 Capital Budget Request

Request Year: 2025

Department: Aviation

Project Name: General Aviation North Apron Reconstruction (Construction/Inspection)

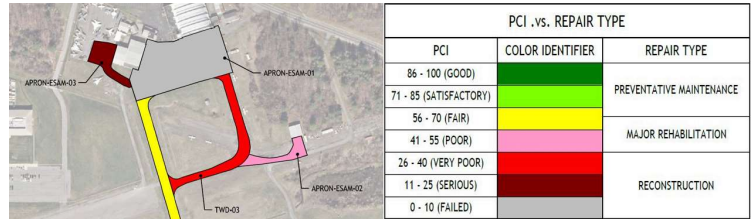

Classification: Project

Type: New

Estimated Start: 8/1/2025

Estimated Completion: 4/1/2026

Estimated Cost: \$6,413,000

Federal Funding	State Funding	County Funding
\$6,092,350	\$0	\$320,650

Project Description:

This project includes the construction and construction administration/inspection for the reconstruction of the General Aviation (GA) North Apron and adjacent jug-handle taxi lane. Reconstruction of the existing apron's asphalt (550ft x 250ft) and jug-handle taxi lane (850ft x 45ft) includes full-depth removal of the existing pavement section (asphalt and subbase stone), replacement of new structural subbase, crushed aggregate base course and bituminous asphalt paving. This project also includes the repair/maintenance of existing drainage, installation of a new storm water retention structure for climate resiliency and reconstruction of apron lighting, security gate access and placement of Federal Aviation Administration(FAA) required pavement markings.

Justification:

The associated apron and taxi lane have exceeded their 20-year design life while also degrading to an average Pavement Condition Index (PCI) of approximately 17-20 (serious). A PCI is a rating from 0 (failed) to 100 (new), the current condition of the asphalt risks damage to any aircraft that travels over it under their own power. This is the final section of the airports existing asphalt that hasn't been upgraded within the last 20 years. Once this is completed, the average PCI rating of the airport will be 85+ (good-new). With a reconstruction project, New York State Department of Transportation and the FAA require a percentage of the asphalt be treated as new for storm water purposes. This is to reduce down stream runoff and flooding potential caused by increased rain events.



Schenectady County 2025 Capital Budget Request

Request Year: 2025
Department: Aviation
Project Name: Storage Building for Airport Equipment
Classification: Project
Type: New



Estimated Start: 4/1/2025 **Estimated Completion:** 10/1/2025
Estimated Cost: \$1,100,000

Federal Funding	State Funding	County Funding
\$0	\$0	\$1,100,000

Project Description:

Construction of a new airport maintenance storage building to house maintenance equipment during the winter months. The building will be approximately 100 feet long by 25 feet deep.

Justification:

The airport mowers are currently stored in an old storage building between Taxiway "E" and the properties along Habel Lane. The County is in the process of amending our lease with the Air National Guard to expand their current leased area. The area where the existing storage building is located will become part of the Air National Guard lease and the buildings will be removed. A new storage building will be needed to house all current and future equipment when not in use.



Schenectady County 2025 Capital Budget Request

Request Year: 2025

Department: Engineering and Public Works

Project Name: County Highway Improvements/County-Wide Highway System

Classification: Project

Type: Replacement/Renewal



Estimated Start: 4/1/2025 **Estimated Completion:** 10/31/2025

Estimated Cost: \$5,376,000

Federal Funding	State Funding	County Funding
\$0	\$3,376,000	\$2,000,000

Project Description:

2025 repaving and reconstruction of the County's highways.

Justification:

Articles 5 & 6 of the New York State Highway Law.



Schenectady County 2025 Capital Budget Request

Request Year: 2025
Department: Facilities
Project Name: 797 Broadway: HVAC Controls Change Out
Classification: Project
Type: New



Estimated Start: 1/1/2025 **Estimated Completion:** 12/31/2025
Estimated Cost: \$300,000

Federal Funding	State Funding	County Funding
\$0	\$0	\$300,000

Project Description:

In 2024, Facilities hired an engineering firm to look at the existing controls and how to best replace them for a more manageable and easy to use controls system.

Replace obsolete HVAC controls no longer serviceable.

Justification:

Current controls are in efficient and are causing constant vendor calls unnecessarily for simple change overs or issues.



Schenectady County 2025 Capital Budget Request

Request Year: 2025

Department: Facilities

Project Name: Aviation: Roof Replacement Project at the Airport Tower

Classification: Project

Type: New



Estimated Start: 5/1/2025 **Estimated Completion:** 10/1/2025

Estimated Cost: \$250,000

Federal Funding	State Funding	County Funding
\$0	\$0	\$250,000

Project Description:

The project involves the replacement of the existing rubber membrane roof and the rubber membrane on the catwalk that surrounds the tower cab.

Justification:

The current roof, now over 25 years old, has been subject to periodic leaks. Notably, the catwalk roof above the airport equipment room has been leaking, leading to water intrusion into the equipment area. This roof has reached the end of its service life and requires replacement to prevent further damage and ensure the protection of essential equipment.



Schenectady County 2025 Capital Budget Request

Request Year: 2025
Department: Facilities
Project Name: Business Center: Fire Alarm Replacement
Classification: Project
Type: New



Estimated Start: 1/1/2025 **Estimated Completion:** 12/31/2025
Estimated Cost: \$100,000

Federal Funding	State Funding	County Funding
\$0	\$0	\$100,000

Project Description:

Replace outdated fire alarm panel at the Schenectady County Business Center

Justification:

Current system is outdated and needs to be replaced and brought up to code.



Schenectady County 2025 Capital Budget Request

Request Year: 2025

Department: Facilities

Project Name: Courthouse & COB Fire System Separation Design Year

Classification: Project

Type: Replacement/Renewal

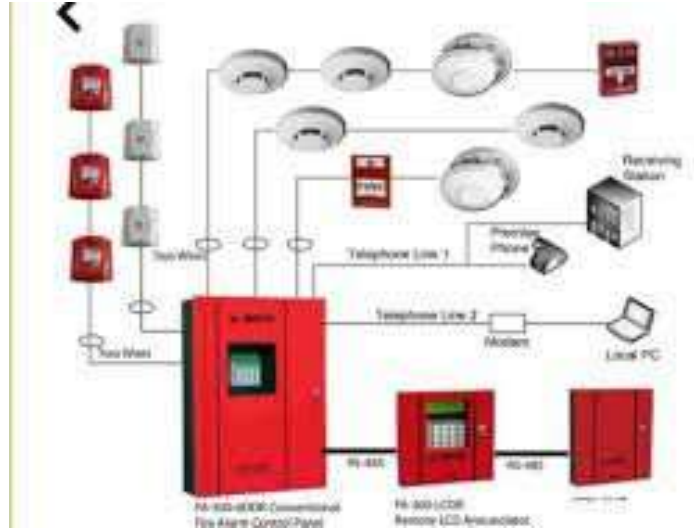

Estimated Start: 1/1/2025 **Estimated Completion:** 12/31/2025

Estimated Cost: \$70,000

Federal Funding	State Funding	County Funding
\$0	\$0	\$70,000

Project Description:

This study will look into the needed separation of the COB and Courthouse to have their own fire panel systems, this will include all new wiring, panels and devices. This will be the first phase needed for the next year to separate the buildings.

Justification:

Both buildings are required by code to have stand alone fire alarm systems.



Schenectady County 2025 Capital Budget Request

Request Year: 2025
Department: Facilities
Project Name: Courthouse Basement
Area & Mechanical Room
Phase 3
Classification: Project
Type: Replacement/Renewal



Estimated Start: 1/1/2025 **Estimated Completion:** 12/31/2025
Estimated Cost: \$300,000

Federal Funding	State Funding	County Funding
\$0	\$0	\$300,000

Project Description:

We will hire an abatement company to come in and abate above the ceiling and any necessary insulation. This will require some mechanical and electrical rewiring and piping during the abatement.

Justification:

There is hazardous material above the ceiling and around associated piping which drives cost for repairs and modifications in the boiler room.



Schenectady County 2025 Capital Budget Request

Request Year: 2025
Department: Facilities
Project Name: Jail: Build Shed w/
Lighting for Storage in
Blue Lot
Classification: Project
Type: New



Estimated Start: 1/1/2025

Estimated Completion: 12/31/2025

Estimated Cost: \$15,000

Federal Funding	State Funding	County Funding
\$0	\$0	\$15,000

Project Description:

Jail is in desperate need of storage.

Justification:

Current jail facility does not have the proper amount of storage.



Schenectady County 2025 Capital Budget Request

Request Year: 2025

Department: Facilities

Project Name: Jail: Cell Night Lights

Classification: Project

Type: New



Estimated Start: 1/1/2025

Estimated Completion: 12/31/2025

Estimated Cost: \$300,000

Federal Funding	State Funding	County Funding
\$0	\$0	\$300,000

Project Description:

As identified by jail administration, this area of the cell is very dark which creates a security risk.

Justification:

The addition of night lights will create proper illumination and supervision over inmates by jail staff, allowing them to better react if needed.



Schenectady County 2025 Capital Budget Request

Request Year: 2025
Department: Facilities
Project Name: Jail: Dorm Windows Replacement
Classification: Project
Type: Replacement/Renewal



Estimated Start: 1/1/2025 **Estimated Completion:** 12/31/2025
Estimated Cost: \$500,000

Federal Funding	State Funding	County Funding
\$0	\$0	\$500,000

Project Description:

Current windows provide a security risk with hiding places for contraband. Jail administration wants them replaced as soon as possible.

Justification:

Current windows are not safe and secure and at the end of their lifespan.



Schenectady County 2025 Capital Budget Request

Request Year: 2025

Department: Facilities

Project Name: Jail: Drains and
Penthouse

Classification: Project

Type: Replacement/Renewal

Estimated Start: 1/1/2025

Estimated Completion: 12/31/2025

Estimated Cost: \$50,000



Federal Funding	State Funding	County Funding
\$0	\$0	\$50,000

Project Description:

Review and repair non-functioning drains.

Justification:

There are numerous drains that are either not working or broken that need to get repaired.



Schenectady County 2025 Capital Budget Request

Request Year: 2025

Department: Facilities

Project Name: Jail: Fires Sprinkler Head Change Out



Classification: Project

Type: New

Estimated Start: 1/1/2025

Estimated Completion: 12/31/2025

Estimated Cost: \$75,000

Federal Funding	State Funding	County Funding
		\$75,000

Project Description:

Changing out different sprinkler heads in the cells and open space areas to approved sprinkler heads for correctional facilities.

Justification:

Changing out outdated sprinkler heads to correctional facility approved heads.



Schenectady County 2025 Capital Budget Request

Request Year: 2025
Department: Facilities
Project Name: Jail: Flush Valves Phase 2
Classification: Project
Type: Replacement/Renewal



Estimated Start: 1/1/2025 **Estimated Completion:** 12/31/2025
Estimated Cost: \$500,000

Federal Funding	State Funding	County Funding
\$0	\$0	\$500,000

Project Description:

Continuation of Phase 1, this project will continue to change our current inmate flush valves to tamper-proof.

Justification:

With the current flush valves, inmates are able to flush multiple times in a short timespan which backs up, causing the toilets to overflow and water to spill everywhere, resulting in significant damage to the floor below. These new valves are designed to be in a jail and have a timing system where they will not be able to do this.



Schenectady County 2025 Capital Budget Request

Request Year: 2025
Department: Facilities
Project Name: Jail: Repair Brick w/
Stainless Steel Guard
Exterior Visitor Area
Classification: Project
Type: Replacement/Renewal



Estimated Start: 1/1/2025 **Estimated Completion:** 12/31/2025
Estimated Cost: \$30,000

Federal Funding	State Funding	County Funding
\$0	\$0	\$30,000

Project Description:

In the Sally Port, the exterior brick of the building coming through the gate needs to be replaced and repointed, and a steel guard add to properly protect the building from damage.

Justification:

Corner of building in sally port constantly gets hit/damaged by delivery trucks.



Schenectady County 2025 Capital Budget Request

Request Year: 2025

Department: Facilities

Project Name: Jail: Sally Port W1 Gate
Demolition & Replacement

Classification: Project

Type: Replacement/Renewal



Estimated Start: 1/1/2025

Estimated Completion: 12/31/2025

Estimated Cost: \$125,000

Federal Funding	State Funding	County Funding
\$0	\$0	\$125,000

Project Description:

Have a contractor come in and replace the main gate and associated controls.

Justification:

Existing gate is at the end of its useful life. For proper security, it needs to be replaced.



Schenectady County 2025 Capital Budget Request

Request Year: 2025

Department: Facilities

Project Name: Library: Bookdrops Project

Classification: Project

Type: New



Estimated Start: 1/1/2025 **Estimated Completion:** 12/31/2025

Estimated Cost: \$50,000

Federal Funding	State Funding	County Funding
\$0	\$0	\$50,000

Project Description:

Rotterdam - Drive-up book drop box, Woodlawn - book drop, Mont Pleasant - book drop, Niskayuna - Book drop, Glenville - Book drop, Scotia - Book drop, KBJ - Book drop

Justification:

The addition of drive up book drops allows for faster returns and accessibility for patrons that can not walk long distances.



Schenectady County 2025 Capital Budget Request

Request Year: 2025

Department: Facilities

Project Name: Library: Fire Panels Phase 2

Classification: Project

Type: New



Estimated Start: 1/1/2025 **Estimated Completion:** 12/31/2025

Estimated Cost: \$200,000

Federal Funding	State Funding	County Funding
\$0	\$0	\$200,000

Project Description:

Continuation for the replacing of old and outdated fire alarm systems at the libraries.

Justification:

For health and safety, it is important to replace old and obsolete panels to meet code. As we continue to upgrade these panels, it will also help minimize maintenance calls.



Schenectady County 2025 Capital Budget Request

Request Year: 2025

Department: Facilities

Project Name: Library: Signage Project Phase 1

Classification: Project

Type: New



Estimated Start: 1/1/2025 **Estimated Completion:** 12/31/2025

Estimated Cost: \$60,000

Federal Funding	State Funding	County Funding
\$0	\$0	\$60,000

Project Description:

Rotterdam - signage, Woodlawn - signage building/monument, Niskayuna - signage, Glenville - signage, KBJ signage

Justification:

Current signage is unreadable or missing and does not tell you what building you are at.



Schenectady County 2025 Capital Budget Request

Request Year: 2025

Department: Facilities

Project Name: Library: Woodlawn Library
Feasibility Study for
Quaker & Woodlawn
Expansion

Classification: Project

Type: New



Estimated Start: 1/1/2025

Estimated Completion: 12/31/2025

Estimated Cost: \$75,000

Federal Funding	State Funding	County Funding
\$0	\$0	\$75,000

Project Description:

Feasibility study for additional program room, possible land purchase or parking lease to accommodate expansion at Woodlawn & Quaker.

Justification:

Current program space is inadequate for current patron attendance.



Schenectady County 2025 Capital Budget Request

Request Year: 2025

Department: Facilities

Project Name: Unified Communication
Center: HVAC upgrade
Phase 1

Classification: Project

Type: New

Estimated Start: 1/1/2025

Estimated Completion: 12/31/2025

Estimated Cost: \$75,000



Federal Funding	State Funding	County Funding
\$0	\$0	\$75,000

Project Description:

Replace dated HVAC equipment.

Justification:

Current HVAC condensers are faulty and are intermittently causing problems at a high-risk facility.



Schenectady County 2025 Capital Budget Request

Request Year: 2025
Department: Glendale Nursing Home
Project Name: Glendale: Garage
Classification: Project
Type: New



Estimated Start: 1/1/2025 **Estimated Completion:** 12/31/2025
Estimated Cost: \$500,000

Federal Funding	State Funding	County Funding
\$0	\$0	\$500,000

Project Description:

Garage needed for storage of landscaping equipment.

Justification:

Current garage no longer useable at current location.



Schenectady County 2025 Capital Budget Request

Request Year: 2025
Department: Information Services
Project Name: IT Security Tools
Classification: Project
Type: New



Estimated Start: 1/1/2025 **Estimated Completion:** 12/31/2025
Estimated Cost: \$70,000

Federal Funding	State Funding	County Funding
\$0	\$0	\$70,000

Project Description:

IT Security Tools. Implementation of new security software.

Justification:

Tools to strengthen and enhance Schenectady County's security posture.



Schenectady County 2025 Capital Budget Request

Request Year: 2025

Department: Schenectady County
Community College

Project Name: Begley Basement
Renovation

Classification: Project

Type: Replacement/Renewal



Estimated Start: 4/1/2025 **Estimated Completion:** 6/30/2026

Estimated Cost: \$1,500,000

Federal Funding	State Funding	County Funding
\$0	\$750,000	\$750,000

Project Description:

Replacement of the Begley Basement Garage Floor and peripherals.

Justification:

The Begley Basement is in poor shape due to water intrusion and poor construction. Metal rebar is protruding through the basement floor surface creating a tripping hazard and overall floor deterioration. A study of the basement was conducted in 2023-24 determining the drainage systems, floor and subsurface require replacement.



Schenectady County 2025 Capital Budget Request

Request Year: 2025

Department: Schenectady County
Community College

Project Name: Culinary Program Kitchen
Ventilation & Dining Room
Renovation

Classification: Project

Type: Existing



Estimated Start: 4/1/2025 **Estimated Completion:** 6/30/2026

Estimated Cost: \$600,000

Federal Funding	State Funding	County Funding
\$0	\$300,000	\$300,000

Project Description:

Replacement of failed kitchen air ventilation systems and renovation of the culinary dining room.

Justification:

The ventilation systems in the culinary banquet kitchens have failed and require replacement. Ventilation is necessary to exhaust fumes and harmful smoke. Project also includes renovation of the culinary dining room which is in need of restoration due to age and outdated finishes.



Schenectady County 2025 Capital Budget Request

Request Year: 2025

Department: Schenectady County
Community College

Project Name: Elston Hall: Gathering
Area and Kitchen
Renovation

Classification: Project

Type: Existing



Estimated Start: 4/1/2025 **Estimated Completion:** 6/30/2026

Estimated Cost: \$1,250,000

Federal Funding	State Funding	County Funding
\$0	\$625,000	\$625,000

Project Description:

Replacement of outdated commercial kitchen equipment, floors, ceilings and utilities in the cafeteria area and renovation of the large cafeteria/gathering area in Elston Hall

Justification:

The cafeteria kitchen area constructed in 1992 has exceeded its useful life. Commercial kitchen equipment is failing and cannot be repaired. Ceiling, floor and wall finishes require replacement. The gathering/cafeteria area is being converted into a usable space for student use and activities.



Schenectady County 2025 Capital Budget Request

Request Year: 2025

Department: Schenectady County
Community College

Project Name: Mechanical, Electrical,
and Plumbing Study

Classification: Project

Type: Study/Design



Estimated Start: 4/1/2025 **Estimated Completion:** 6/30/2026

Estimated Cost: \$50,000

Federal Funding	State Funding	County Funding
\$0	\$25,000	\$25,000

Project Description:

Development of a 5 to 10 year Mechanical, Electrical and Plumbing (MEP) facilities master plan to forecast future capital project needs to maintain the college's physical plant.

Justification:

The college's physical plant ranges in age from 25 to 100 years old requiring frequent maintenance and capital investments. A comprehensive MEP study will provide a guide for future capital projects to ensure facilities are in good working order and to help forecast capital cost investment.

CAPITAL EQUIPMENT REQUESTS 2025



Schenectady County 2025 Capital Budget Request

Request Year: 2025
Department: Board of Elections
Project Name: New Voting Machines
Classification: Equipment
Type: Replacement/Renewal



Estimated Start: 3/1/2025 **Estimated Completion:** 12/31/2025
Estimated Cost: \$1,000,000

Federal Funding	State Funding	County Funding
\$0	\$0	\$1,000,000

Project Description:

New voting machines for the county in addition to new software to support.

Justification:

Current voting machines are at end of life. If grant money becomes available, the amount requested from the county will be reduced.



Schenectady County 2025 Capital Budget Request

Request Year: 2025

Department: Engineering and Public Works

Project Name: DEPW: Refurbish Equipment

Classification: Equipment

Type: Replacement/Renewal



Estimated Start: 1/1/2025 **Estimated Completion:** 12/31/2025

Estimated Cost: \$100,000

Federal Funding	State Funding	County Funding
\$0	\$0	\$100,000

Project Description:

Refurbishment will be completed on multiple trucks along with multiple plows & wings

Justification:

To extend the useful life of these units by a minimum of 5 years



Schenectady County 2025 Capital Budget Request

Request Year: 2025

Department: Engineering and Public Works

Project Name: Equipment: New 2025 Guardrail Post Pounder, GRT Utilicorp

Classification: Equipment

Type: Replacement/Renewal



Estimated Start: 1/1/2025 **Estimated Completion:** 12/31/2025

Estimated Cost: \$255,000

Federal Funding	State Funding	County Funding
\$0	\$0	\$255,000

Project Description:

New 2025 Guardrail Post Pounder, GRT Utilicorp

Justification:

This will replace 1015/1287 a 1994 post pounder which has a lot of wear and tear, leaking valves, many hours on it and needs to be replaced.



Schenectady County 2025 Capital Budget Request

Request Year: 2025

Department: Engineering and Public Works

Project Name: Fleet Replacement:
General County Inventory

Classification: Equipment

Type: Replacement/Renewal



Estimated Start: 1/1/2025 **Estimated Completion:** 12/31/2025

Estimated Cost: \$395,000

Federal Funding	State Funding	County Funding
\$0	\$0	\$395,000

Project Description:

The Department of Engineering and Public Works manages the County fleet and recommends when replacement of vehicles is necessary. The County vehicle fleet is managed as one large pool of vehicles and assigned as needed.

For the list of vehicles to be purchased, please see the Vehicle Fleet Replacement table on page 6.

Justification:

These will replace vehicles that are nearing their end-of-life.



Schenectady County 2025 Capital Budget Request

Request Year: 2025

Department: Engineering and Public Works

Project Name: Fleet Replacement: MV 607 SBA 4x2 Crew Truck with Dump Body

Classification: Equipment

Type: Replacement/Renewal



Estimated Start: 1/1/2025 **Estimated Completion:** 12/31/2025

Estimated Cost: \$145,000

Federal Funding	State Funding	County Funding
\$0	\$0	\$145,000

Project Description:

MV 607 SBA 4x2 Crew Truck with Dump Body

Justification:

This new unit will replace 1049, a 2011 4300 International with approx. 180,000 miles at the time of replacement. 1049 will replace 1048 which is being used for a water truck. 1048 will be used as an extra for now, it may go to auction in the future.



Schenectady County 2025 Capital Budget Request

Request Year: 2025

Department: Engineering and Public Works

Project Name: Fleet Replacement: New 2025 DD25B Volvo Asphalt Roller

Classification: Equipment

Type: Replacement/Renewal



Estimated Start: 1/1/2025 **Estimated Completion:** 12/31/2025

Estimated Cost: \$52,000

Federal Funding	State Funding	County Funding
\$0	\$0	\$52,000

Project Description:

New 2025 DD25B Volvo Asphalt Roller

Justification:

This unit will replace 1261, a 1990 Ingersol road roller which has over 3100 hours on it and is 34 years old. This unit will go to auction.



Schenectady County 2025 Capital Budget Request

Request Year: 2025

Department: Engineering and Public Works

Project Name: Fleet Replacement: New 2025 HV507 SFA Single Axle Dump Truck

Classification: Equipment

Type: Replacement/Renewal

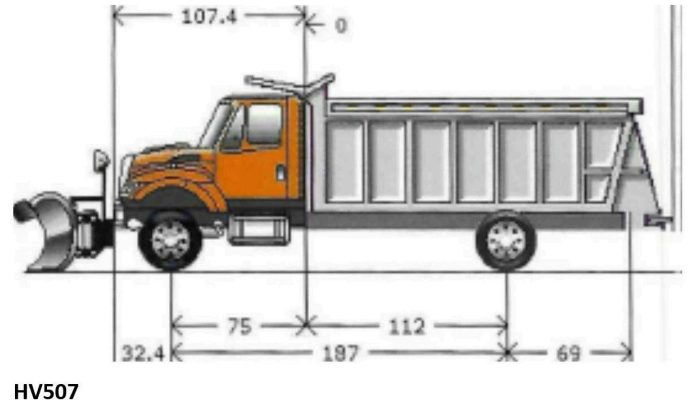

Estimated Start: 1/1/2025 **Estimated Completion:** 12/31/2025

Estimated Cost: \$275,000

Federal Funding	State Funding	County Funding
\$0	\$0	\$275,000

Project Description:
 New 2025 HV507 SFA single axle dump truck with snow & ice equipment, auto chains, 2-way radio

Justification:
 This will replace 1152, a 2011 International with approximately 95,000 miles at time of replacement. Vehicle 1152 will become a spare.



Schenectady County 2025 Capital Budget Request

Request Year: 2025

Department: Engineering and Public Works

Project Name: Fleet Replacement: New 2025 HX520 SFA Tandem Dump Truck

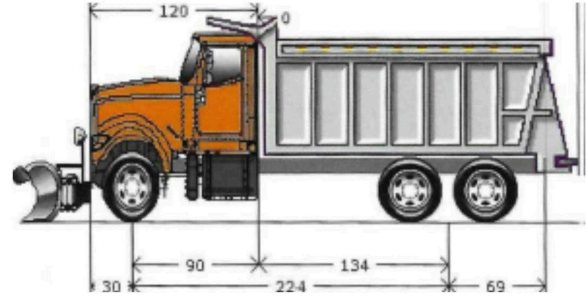

Classification: Equipment

HX520

Type: Replacement/Renewal

Estimated Start: 1/1/2025

Estimated Completion: 12/31/2025

Estimated Cost: \$330,000

Federal Funding	State Funding	County Funding
\$0	\$0	\$330,000

Project Description:

New 2025 HX520 SFA Tandem dump truck with snow & ice equip., auto chains, 2-way radio

Justification:

This will replace 1155 and that will become a spare.



Schenectady County 2025 Capital Budget Request

Request Year: 2025

Department: Engineering and Public Works

Project Name: Fleet Replacement: New 2025 International Dump Truck 6x6

Classification: Equipment

Type: Replacement/Renewal

Estimated Start: 1/1/2025

Estimated Completion: 12/31/2025

Estimated Cost: \$300,000

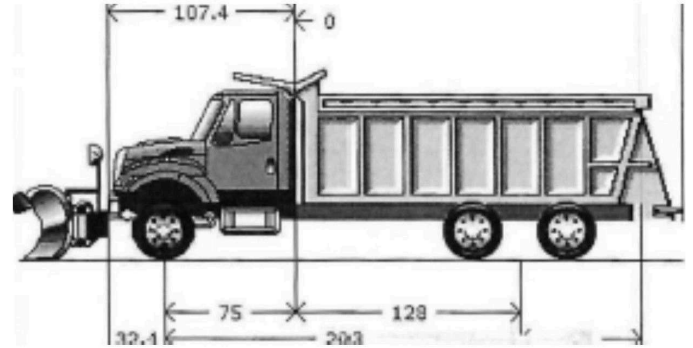

6x6

Federal Funding	State Funding	County Funding
\$0	\$0	\$300,000

Project Description:

New 2025 International dump truck 6x6 with snow & ice equipment, auto chains, 2-way radio

Justification:

This will replace unit 1148, a 2008 International Paystar 6x6 with 116,000 miles at the time of replacement. Vehicle 1148 will be 16 years old and will be used for a spare.



Schenectady County 2025 Capital Budget Request

Request Year: 2025

Department: Engineering and Public Works

Project Name: Fleet Replacement: New 2025 T66 T4 Bobcat Compact Track Loader

Classification: Equipment

Type: Replacement/Renewal



Estimated Start: 1/1/2025 **Estimated Completion:** 12/31/2025

Estimated Cost: \$78,000

Federal Funding	State Funding	County Funding
\$0	\$0	\$78,000

Project Description:

New 2025 T66 T4 Bobcat Compact Track Loader with additional features

Justification:

This unit will replace 1284, a 1996 Bobcat loader with 2100 hours and 28 years old and will go to auction.



Schenectady County 2025 Capital Budget Request

Request Year: 2025

Department: Engineering and Public Works

Project Name: Fleet Replacement: New 2025 Volvo ECR88D Excavator

Classification: Equipment

Type: Replacement/Renewal



Estimated Start: 1/1/2025 **Estimated Completion:** 12/31/2025

Estimated Cost: \$132,000

Federal Funding	State Funding	County Funding
\$0	\$0	\$132,000

Project Description:

New 2025 Volvo ECR88D Excavator

Justification:

This unit will replace 1238 a 1994 JCB Backhoe which is 30 years old, has 3200 hours on it and has electrical issues. Unit 1245 will take its place and this new unit will take 1245's place. Unit 1238 will go to auction.



Schenectady County 2025 Capital Budget Request

Request Year: 2025
Department: Glendale Nursing Home
Project Name: Fleet Replacement:
Glendale 2025 2500
Chevy or Ford F-250
Classification: Equipment
Type: Replacement/Renewal



Estimated Start: 1/1/2025 **Estimated Completion:** 12/31/2025
Estimated Cost: \$59,000

Federal Funding	State Funding	County Funding
\$0	\$0	\$59,000

Project Description:

2025 2500 Chevy or Ford F-250 Regular Cab with V-Plow

Justification:

Unit 2426 will be 25 years old at the time of replacement and has significant rusting. Unit 2426 will go to auction.



Schenectady County 2025 Capital Budget Request

Request Year: 2025
Department: Information Services
Project Name: Network Switch Upgrade
Classification: Equipment
Type: Replacement/Renewal



Estimated Start: 1/1/2025 **Estimated Completion:** 12/31/2025
Estimated Cost: \$100,000

Federal Funding	State Funding	County Funding
\$0	\$0	\$100,000

Project Description:

Implement network switch upgrades.

Justification:

Replace network switches as needed based on age.



Schenectady County 2025 Capital Budget Request

Request Year: 2025
Department: Information Services
Project Name: Network Test Equipment
Classification: Equipment
Type: Existing



Estimated Start: 1/1/2025 **Estimated Completion:** 12/31/2025
Estimated Cost: \$45,000

Federal Funding	State Funding	County Funding
\$0	\$0	\$45,000

Project Description:

Purchase network test equipment.

Justification:

Equipment required to test and scan network.



Schenectady County 2025 Capital Budget Request

Request Year: 2025

Department: Purchasing

Project Name: Copiers and Equipment

Classification: Equipment

Type: Replacement/Renewal



Estimated Start: 1/1/2025

Estimated Completion: 12/31/2025

Estimated Cost: \$30,000

Federal Funding	State Funding	County Funding
\$0	\$0	\$30,000

Project Description:

Replacement of copiers and other large office equipment.

Justification:

As office equipment ages out, or fails, new equipment must be purchased. This capital fund will be available to replace a copier or items of this nature.



Schenectady County 2025 Capital Budget Request

Request Year: 2025

Department: Sheriff - All Divisions

Project Name: Sheriff Dept.: 2025 Ford Explorer for Task Force Unit

Classification: Equipment

Type: New



Estimated Start: 1/1/2025 **Estimated Completion:** 12/31/2025

Estimated Cost: \$65,000

Federal Funding	State Funding	County Funding
\$0	\$0	\$65,000

Project Description:

Task Force unit - 2025 Ford Explorer with standard features and emergency lights.

Justification:

New to the fleet - for the Task Force.



Schenectady County 2025 Capital Budget Request

Request Year: 2025

Department: Sheriff - All Divisions

Project Name: Sheriff Dept.: Vehicle Replacements and Upfitting

Classification: Equipment

Type: New



Estimated Start: 1/1/2025 **Estimated Completion:** 12/31/2025

Estimated Cost: \$304,000

Federal Funding	State Funding	County Funding
\$0	\$0	\$304,000

Project Description:

The Department of Engineering and Public Works manages the Sheriff's Department's fleet and recommends when replacement of vehicles is necessary. For 2025, the Sheriff's request is for:

- Three (3) Patrol Interceptors with upfitting. Upfitting will include Panasonic Toughbook laptops and docking stations.
- One (1) Chevy 3500 Express Van with standard options and police features.

Justification:

These Interceptors will potentially replace vehicles that are nearing their end-of-life. (#2389 and #2360)
 The Chevy Van will replace 2378, which will have approx. 150,000 miles at time of replacement. 2378 will replace 3612, a 2005 Chevy Express Van that will go to auction.

**FUTURE CAPITAL PLAN REQUESTS
2026-2030**



Schenectady County 2025 Capital Budget Request

Request Year: 2026

Department: Facilities

Project Name: Business Center: Exterior Rehabilitation



Classification: Project

Type: New

Estimated Start: 1/1/2026

Estimated Completion: 12/31/2026

Estimated Cost: \$150,000

Federal Funding	State Funding	County Funding
\$0	\$0	\$150,000

Project Description:

Exterior dryvit is stained badly which makes it unsightly.

Justification:

Fixing exterior dryvit will improve building condition.



Schenectady County 2025 Capital Budget Request

Request Year: 2026
Department: Facilities
Project Name: Business Center: Interior Upgrades
Classification: Project
Type: Replacement/Renewal



Estimated Start: 1/1/2026 **Estimated Completion:** 12/31/2026
Estimated Cost: \$30,000

Federal Funding	State Funding	County Funding
\$0	\$0	\$30,000

Project Description:

Install crash rails and FRP in all common area hallways.

Justification:

To prevent further damage to interior walls from pallet jacks and other machinery.



Schenectady County 2025 Capital Budget Request

Request Year: 2026

Department: Facilities

Project Name: County Office Building:
Streetscape Phase 2
(Courthouse & 608 State)

Classification: Project

Type: New



Estimated Start: 1/1/2026 **Estimated Completion:** 12/31/2026

Estimated Cost: \$750,000

Federal Funding	State Funding	County Funding
\$0	\$0	\$750,000

Project Description:

Courthouse Façade Restoration and 608 State Street Ramp and Façade Work. This involves adding stabilization or removal of the upper floor porches.

Justification:

The Courthouse needs to have restorative work completed in numerous areas of the building. The 608 State Street retaining wall, ramp, and exterior façade work are in need of attention. The Front of the County Office Building and Courthouse need restorative work and fixing of patio pavers.



Schenectady County 2025 Capital Budget Request

Request Year: 2026

Department: Facilities

Project Name: Courthouse Exterior
Masonry

Classification: Project

Type: Replacement/Renewal



Estimated Start: 1/1/2026 **Estimated Completion:** 12/31/2026

Estimated Cost: \$1,000,000

Federal Funding	State Funding	County Funding
\$0	\$0	\$1,000,000

Project Description:

Phase 1 of mason exterior repairs as mentioned in the four-building survey study. Replace limestone, brick and mortar repairs patch as needed.

Justification:

As part of restorative maintenance to the Courthouse to prevent falling debris and increase lighting to create a secure environment. The back of the courthouse brick façade is bowing and showing signs of extreme water infiltration, this is a safety concern and needs to be addressed.



Schenectady County 2025 Capital Budget Request

Request Year: 2026

Department: Facilities

Project Name: Courthouse Facade Renovation

Classification: Project

Type: New



Estimated Start: 1/1/2026 **Estimated Completion:** 12/31/2026

Estimated Cost: \$1,000,000

Federal Funding	State Funding	County Funding
\$0	\$0	\$1,000,000

Project Description:

Routine Maintenance and Repairs of the Cast Stone and Cornices

Justification:

As the building ages, it is necessary to do repairs and replacements of certain cast stone pieces. The higher up these pieces are, the harder it is to replace. With the guidance of the Building Survey, this will be a routine maintenance for the next 5 years.



Schenectady County 2025 Capital Budget Request

Request Year: 2026
Department: Facilities
Project Name: Courthouse Lobby refresh
PH1 & Reimagine Historic
Classification: Project
Type: Replacement/Renewal



Estimated Start: 1/1/2026 **Estimated Completion:** 12/31/2026
Estimated Cost: \$1,500,000

Federal Funding	State Funding	County Funding
\$0	\$0	\$1,500,000

Project Description:

Bring lobby back to historical look and feel.

Justification:

Interior finishes are tired and mask historic value of the Courthouse.



Schenectady County 2025 Capital Budget Request

Request Year: 2026

Department: Facilities

Project Name: Courthouse: Bathroom Renovation Phase 2

Classification: Project

Type: New



Estimated Start: 1/1/2026 **Estimated Completion:** 12/31/2026

Estimated Cost: \$500,000

Federal Funding	State Funding	County Funding
\$0	\$0	\$500,000

Project Description:

Continuation of replacing shared space bathrooms.

Justification:

Current fixtures and bathrooms are antiquated and some fixtures are broken, some piping and drains have to get replaced or relined due to age. Facilities started this in 2024 and is continuing through the rest of the courthouse.



Schenectady County 2025 Capital Budget Request

Request Year: 2026
Department: Facilities
Project Name: Courthouse: Electrical Panel Upgrades
Classification: Project
Type: New



Estimated Start: 1/1/2026 **Estimated Completion:** 12/31/2026
Estimated Cost: \$750,000

Federal Funding	State Funding	County Funding
\$0	\$0	\$750,000

Project Description:

Replacing electrical panels and conduit in the Courthouse.

Justification:

The existing panels are nearing the end of their useful life and will need to be replaced.



Schenectady County 2025 Capital Budget Request

Request Year: 2026
Department: Facilities
Project Name: Courthouse: Exterior Rehabilitation
Classification: Project
Type: New



Estimated Start: 1/1/2026 **Estimated Completion:** 12/31/2026
Estimated Cost: \$750,000

Federal Funding	State Funding	County Funding
\$0	\$0	\$750,000

Project Description:

Repairing broken/cracked/failing stonework along the Courthouse facade, replacing railings, replacing doors, and fixing up the skybridge connecting the jail and the courthouse.

Justification:

Starting with the back and side of the Courthouse, there is façade, brick, and drainage work that needs to be designed and restored. The skybridge connected to the back of the courthouse needs to be power washed, painted, and have some roof restoration due to improper drainage



Schenectady County 2025 Capital Budget Request

Request Year: 2026

Department: Facilities

Project Name: DEPW: Roof Replacement
Barrel Vault Roof



Classification: Project

Type: New

Estimated Start: 1/1/2026

Estimated Completion: 12/31/2026

Estimated Cost: \$1,500,000

Federal Funding	State Funding	County Funding
\$0	\$0	\$1,500,000

Project Description:

Replacement of the barrel vault roofs over the highway garages.

Justification:

The current roof on both garages has exceed its useful life, currently it has several leaks damaging new insulation and is beyond repairable.



Schenectady County 2025 Capital Budget Request

Request Year: 2026

Department: Facilities

Project Name: Jail: Booking Area Refresh

Classification: Project

Type: New



Estimated Start: 1/1/2026 **Estimated Completion:** 12/31/2026

Estimated Cost: \$400,000

Federal Funding	State Funding	County Funding
\$0	\$0	\$400,000

Project Description:

Replace current flooring with durable finishes and revamping paint, ceilings and lights in the processing area.

Justification:

Current processing area is tired paint peeling off floor and walls and ceiling, not enough lights and area is need of reconfiguration for better process flow.



Schenectady County 2025 Capital Budget Request

Request Year: 2026

Department: Facilities

Project Name: Jail: Dorm Hallway Refresh



Classification: Project

Type: Replacement/Renewal

Estimated Start: 1/1/2026

Estimated Completion: 12/31/2026

Estimated Cost: \$150,000

Federal Funding	State Funding	County Funding
\$0	\$0	\$150,000

Project Description:

Hallway walls are in need of repair FRP paneling falling off walls.

Justification:

Paneling can break off and fall down creating a hazardous work environment, needs to be replaced.



Schenectady County 2025 Capital Budget Request

Request Year: 2026
Department: Facilities
Project Name: Jail: Epoxy Floors 1-4
Phase 3
Classification: Project
Type: Replacement/Renewal



Estimated Start: 1/1/2026 **Estimated Completion:** 12/31/2026
Estimated Cost: \$500,000

Federal Funding	State Funding	County Funding
\$0	\$0	\$500,000

Project Description:

This project is the continuation of the Jail Epoxy Flooring Phase 1 project, changing jail flooring from old VCT to epoxy flooring.

Justification:

Epoxy creates a water tight seal and does not break off into dangerous shards. It adheres to the concrete for a 30-50 year finish that can withstand a rough environment. This flooring will be easier to clean and maintain for the facility.



Schenectady County 2025 Capital Budget Request

Request Year: 2026

Department: Facilities

Project Name: Jail: Exterior Phase 3

Classification: Project

Type: Replacement/Renewal

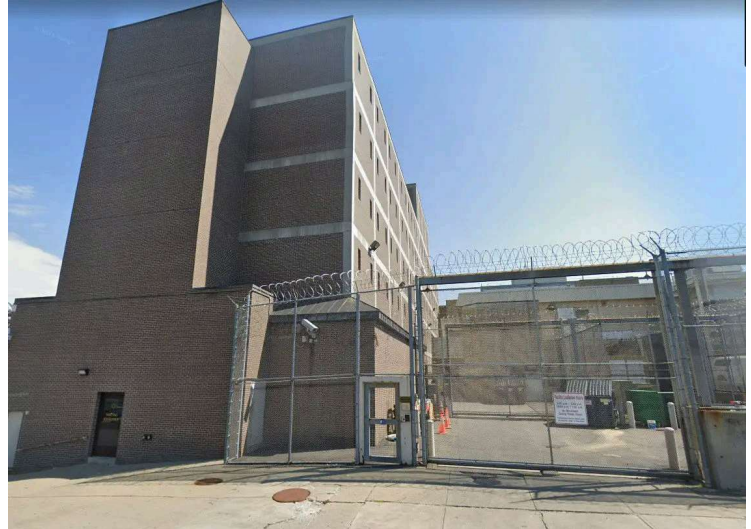

Estimated Start: 1/1/2026 **Estimated Completion:** 12/31/2026

Estimated Cost: \$175,000

Federal Funding	State Funding	County Funding
\$0	\$0	\$175,000

Project Description:

Visitor entrance door, need an ADA ramp and will need to create a flat spot, concrete apron leaving back of jail lot needs to be redone.

Justification:

To meet ADA requirements and correct current safety hazards.



Schenectady County 2025 Capital Budget Request

Request Year: 2026

Department: Facilities

Project Name: Jail: In Depth Design
Study of the Jail



Classification: Project

Type: Study/Design

Estimated Start: 1/1/2026

Estimated Completion: 12/31/2026

Estimated Cost: \$65,000

Federal Funding	State Funding	County Funding
\$0	\$0	\$65,000

Project Description:

A comprehensive study can inform long-term planning efforts by identifying not only immediate needs but also anticipated future requirements for correctional officer workspaces. This can help ensure that investments in workspace refreshment are aligned with the facility's strategic goals and budgetary constraints.

Justification:

In conclusion, a more in-depth study can provide the evidence-based rationale and justification needed to support the refreshment of spaces in jails for staff and inmates, ensuring that resources are allocated effectively and that the initiative contributes to the overall well-being and effectiveness of correctional staff and the institution as a whole.



Schenectady County 2025 Capital Budget Request

Request Year: 2026
Department: Facilities
Project Name: Jail: Locker Room and Administrative Area Refresh
Classification: Project
Type: New



Estimated Start: 1/1/2026 **Estimated Completion:** 12/31/2026
Estimated Cost: \$750,000

Federal Funding	State Funding	County Funding
\$0	\$0	\$750,000

Project Description:

Design started in 2024 for construction but due to the extent of necessary repairs, we will need additional funding to complete the project.

Justification:

The current locker rooms need a complete gut in order to incorporate the necessary repairs and install gender neutral locker room space in the locker room area.



Schenectady County 2025 Capital Budget Request

Request Year: 2026

Department: Facilities

Project Name: Jail: Locker Room Phase 2
and Administration Area

Classification: Project

Type: Replacement/Renewal

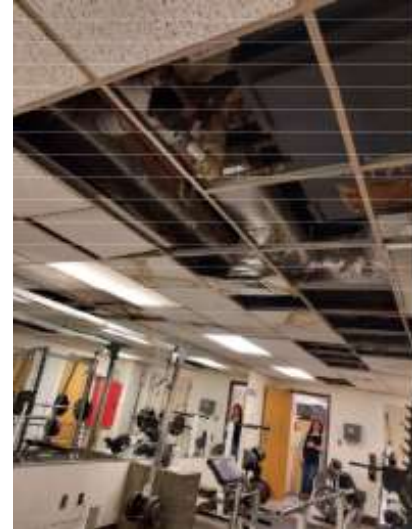

Estimated Start: 1/1/2026

Estimated Completion: 12/31/2026

Estimated Cost: \$750,000

Federal Funding	State Funding	County Funding
\$0	\$0	\$750,000

Project Description:

In 2024, Facilities started the design for the Jail Locker room project but as we started looking into ceilings and piping, it was determined that we would quickly be over budget with the necessary repairs and replacements that need to be made.

Justification:

The Jail locker room is located on the same floor as the Jail Administration in the original (or "old") part of the jail. By refreshing the space, it will improve moral in a high stress field environment.



Schenectady County 2025 Capital Budget Request

Request Year: 2026
Department: Facilities
Project Name: Jail: Parking Lot Lights
Classification: Project
Type: New



Estimated Start: 1/1/2026 **Estimated Completion:** 12/31/2026
Estimated Cost: \$150,000

Federal Funding	State Funding	County Funding
\$0	\$0	\$150,000

Project Description:

Adding parking lot lights to the Union Lots. Two behind the jail and two across the street on Veeder and Albany Street.

Justification:

There is currently insufficient lighting and adding lights will improve and provide safer conditions.



Schenectady County 2025 Capital Budget Request

Request Year: 2026

Department: Facilities

Project Name: Jail: Roof Replacement

Classification: Project

Type: New

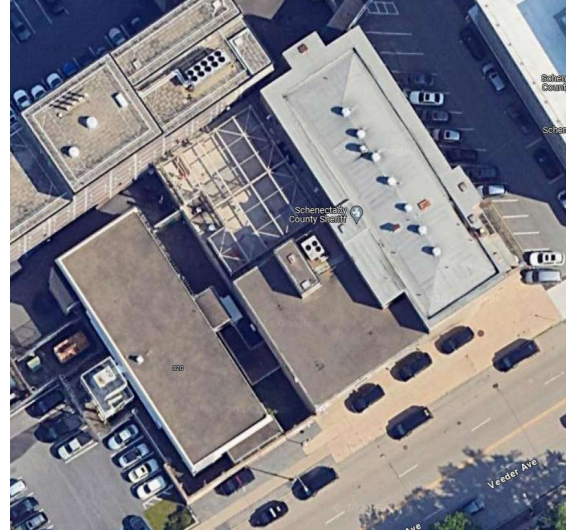

Estimated Start: 1/1/2026 **Estimated Completion:** 12/31/2026

Estimated Cost: \$55,000

Federal Funding	State Funding	County Funding
		\$55,000

Project Description:

The old Jail Roof and the Dorm roofs are at the end of their useful life and need to be replaced.

Justification:

This project will encompass design, testing, and construction to replace these roofs.



Schenectady County 2025 Capital Budget Request

Request Year: 2026
Department: Facilities
Project Name: Library: Branch Library
Parking Lot Sealant
Classification: Project
Type: Replacement/Renewal



Estimated Start: 1/1/2026 **Estimated Completion:** 12/31/2026
Estimated Cost: \$75,000

Federal Funding	State Funding	County Funding
\$0	\$0	\$75,000

Project Description:

This project is a continuation using crack fill, seal, re-striped, and coat the parking lots of all of the branch libraries.

Justification:

Continuation maintain parking lots, they should be crack filled, sealed, re-striped, and coated to prevent early replacement of parking lots and major patches in th future.



Schenectady County 2025 Capital Budget Request

Request Year: 2026
Department: Facilities
Project Name: Library: Exterior Project Phase 1
Classification: Project
Type: New



Estimated Start: 1/1/2026 **Estimated Completion:** 12/31/2026
Estimated Cost: \$150,000

Federal Funding	State Funding	County Funding
\$0	\$0	\$150,000

Project Description:

Rotterdam - Landscaping, pressure wash building, Woodlawn - Landscaping retaining wall failing Niskayuna - pressure wash exterior, Scotia - cleanup outside, pressure wash front & back entrances.

Justification:

Necessary improvements for the bettering of the Library systems. At Woodlawn, the retaining wall is failing and needs to be redone.



Schenectady County 2025 Capital Budget Request

Request Year: 2026

Department: Facilities

Project Name: Library: Interior Project
Various Branches Phase 1

Classification: Project

Type: New



Estimated Start: 1/1/2026 **Estimated Completion:** 12/31/2026

Estimated Cost: \$300,000

Federal Funding	State Funding	County Funding
\$0	\$0	\$300,000

Project Description:

Rotterdam - bottle filler fountain, build breakroom wall, Mont Pleasant - paint wall where divider peeled paint off and fix divider wall, Niskayuna - replace windows in reading nook both sides & breakroom windows, Refresh breakroom, Misc. - Review staff break areas for all locations, continue furniture replacement, replace water fountains with bottle fillers all locations

Justification:

Necessary interior improvements to better patrons and staff environment.



Schenectady County 2025 Capital Budget Request

Request Year: 2026

Department: Facilities

Project Name: Library: KBJ Library 2nd Floor Design Year

Classification: Project

Type: New



Estimated Start: 1/1/2026 **Estimated Completion:** 12/31/2026

Estimated Cost: \$50,000

Federal Funding	State Funding	County Funding
\$0	\$0	\$50,000

Project Description:

Architect & design fees for feasibility study to rework 2nd floor.

Justification:

Current space is not being used to full capability. A study is needed to see what can be feasibly done.



Schenectady County 2025 Capital Budget Request

Request Year: 2026

Department: Facilities

Project Name: Library: Niskayuna Branch
Parking Lights &
Sidewalks Phase 2



Classification: Project

Type: New

Estimated Start: 1/1/2026

Estimated Completion: 12/31/2026

Estimated Cost: \$130,000

Federal Funding	State Funding	County Funding
\$0	\$0	\$130,000

Project Description:

Replacement of damaged and unsafe sidewalks. Replacement of old pole lights in parking area for new LED.

Justification:

Current sidewalks are cracked, broken, and unlevel. This creates unsafe walking path. The lights are old and need to be replaced.



Schenectady County 2025 Capital Budget Request

Request Year: 2026

Department: Schenectady County
Community College

Project Name: College-wide Fire Alarm

Classification: Project

Type: Existing



Estimated Start: 4/1/2026 **Estimated Completion:** 6/30/2027

Estimated Cost: \$1,500,000

Federal Funding	State Funding	County Funding
\$0	\$750,000	\$750,000

Project Description:

Replacement of the campus-wide fire alarm system

Justification:

The campus-wide fire alarm system is an older limited system that experiences frequent false alarms and is not integrated. A new system is needed to provide reliable fire protection and that includes a voice annunciator.



Schenectady County 2025 Capital Budget Request

Request Year: 2026

Department: Schenectady County
Community College

Project Name: Data Center Consolidation

Classification: Project

Type: Replacement/Renewal

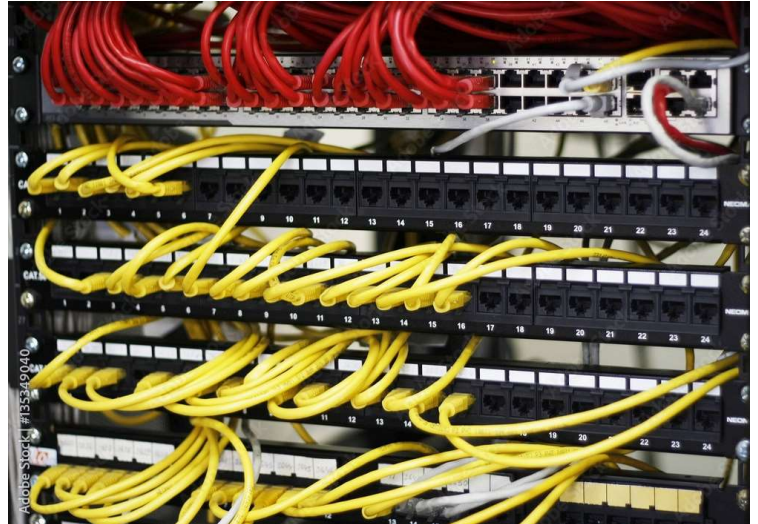

Estimated Start: 4/1/2026 **Estimated Completion:** 6/30/2027

Estimated Cost: \$2,500,000

Federal Funding	State Funding	County Funding
\$0	\$1,250,000	\$1,250,000

Project Description:

Design and construction of a new IT Data Center on the 4th floor of Elston Hall.

Justification:

The IT Data Center will be re-designed and expanded on the 4th floor of Elston Hall. This renovation will permit better configuration of space and allow the entire ITS Department to be co-located on one floor.



Schenectady County 2025 Capital Budget Request

Request Year: 2026

Department: Schenectady County
Community College

Project Name: Daycare Center
Playground & Quad
Beautification

Classification: Project

Type: Replacement/Renewal



Estimated Start: 4/1/2026 **Estimated Completion:** 6/30/2027

Estimated Cost: \$800,000

Federal Funding	State Funding	County Funding
\$0	\$400,000	\$400,000

Project Description:

Replacement of daycare playground equipment that is failing and unsafe for use and replacement of current paving stones and broken concrete walkways/railings in the main quad area.

Justification:

The daycare playground equipment is failing and no longer safe for use. Paving stones, concrete walkways and metal railings in the main quad are broken, cracked from settling or rusted due to age and in need of replacement due to safety issues.



Schenectady County 2025 Capital Budget Request

Request Year: 2026

Department: Schenectady County
Community College

Project Name: Elston Hall: Basement
Hallway Renovation

Classification: Project

Type: Replacement/Renewal

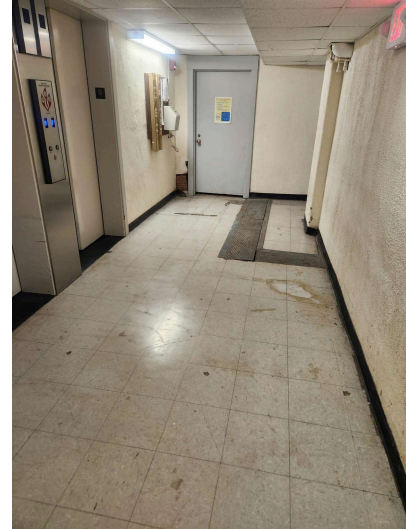

Estimated Start: 4/1/2026 **Estimated Completion:** 6/30/2027

Estimated Cost: \$1,000,000

Federal Funding	State Funding	County Funding
\$0	\$500,000	\$500,000

Project Description:

Renovation of the Elston Hall basement walls, floors, ceilings and lighting. Project includes repair/replacement of a grease trap and building sewer line.

Justification:

The Elston Hall basement hallway is in poor condition due to age and building settling. The project includes replacement of the hallway grease trap which is in poor condition and in need of replacement. Examination and replacement of the building's main sewer line is included due to recent clog/failures. The fit and finish of this main point of egress is needed as the lighting is poor and hallway surfaces are uneven.



Schenectady County 2025 Capital Budget Request

Request Year: 2026

Department: Schenectady County
Community College

Project Name: Elston Hall: Facade &
Window Restoration

Classification: Project

Type: Existing



Estimated Start: 4/1/2026 **Estimated Completion:** 6/30/2027

Estimated Cost: \$2,500,000

Federal Funding	State Funding	County Funding
\$0	\$1,250,000	\$1,250,000

Project Description:

Restoration of the North and South sides of the Elston Hall exterior to include replacement of broken stonework, replacement of the relief angle and re-pointing of brickwork. This includes restoration of the first floor historical windows.

Justification:

This is the second phase of a three phase project to restore the exterior of Elston Hall. During the 2023 project, contractors determined the third floor relief angle required replacement and reattachment to the building. This project will correct that issue, replace broken and cracked cast stone and restore the first floor historic windows of the building.



Schenectady County 2025 Capital Budget Request

Request Year: 2026

Department: Schenectady County
Community College

Project Name: Elston Hall: Student
Affairs Renovation

Classification: Project

Type: Existing



Estimated Start: 4/1/2026 **Estimated Completion:** 6/30/2027

Estimated Cost: \$4,500,000

Federal Funding	State Funding	County Funding
\$0	\$2,250,000	\$2,250,000

Project Description:

Restoration and refinish of the Student Affairs and Counseling area

Justification:

Design and renovation to the second floor of Elston Hall where the Student Affairs and Counseling offices are located. This area was constructed in the late 1960s and is in need of reconfiguration of working areas and replacement of outdated HVAC systems.



Schenectady County 2025 Capital Budget Request

Request Year: 2026

Department: Schenectady County
Community College

Project Name: Elston Hall: Testing Center
Expansion & Renovation

Classification: Project

Type: Replacement/Renewal



Estimated Start: 4/1/2026 **Estimated Completion:** 6/30/2027

Estimated Cost: \$1,600,000

Federal Funding	State Funding	County Funding
\$0	\$800,000	\$800,000

Project Description:

Expansion and renovation of the SUNY Schenectady Testing Center in Elston Hall.

Justification:

The existing Testing Center is located in a 950-square feet area on the 4th floor of Elston Hall. Current location does not provide adequate space for a reception area, office space or disability testing. It will be relocated to the second floor of Elston Hall.



Schenectady County 2025 Capital Budget Request

Request Year: 2026

Department: Schenectady County
Community College

Project Name: Van Curler Room
Restoration

Classification: Project

Type: Replacement/Renewal

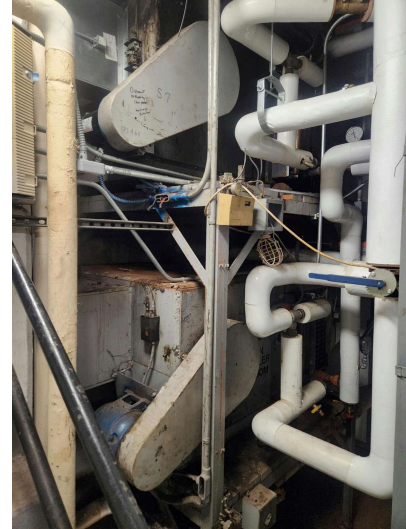

Estimated Start: 4/1/2026 **Estimated Completion:** 6/30/2027

Estimated Cost: \$1,500,000

Federal Funding	State Funding	County Funding
\$0	\$750,000	\$750,000

Project Description:

Restoration and refinish of the Van Curler Ballroom and associated HVAC systems.

Justification:

The Van Curler Room is the college’s main culinary banquet room which is in need of renovation. The room’s fit and finish is dated with a failing center room movable wall which is in need of replacement. The room’s HVAC system requires replacement due to age and failing mechanical systems.



Schenectady County 2025 Capital Budget Request

Request Year: 2026

Department: Unified Communication Center

Project Name: Countywide CAD/RMS

Classification: Project

Type: Replacement/Renewal

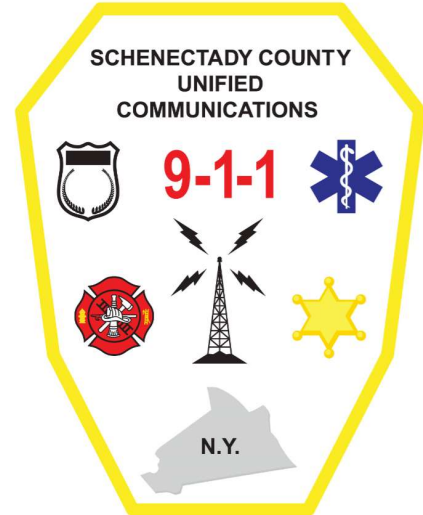

Estimated Start: 1/1/2026 **Estimated Completion:** 12/31/2027

Estimated Cost: \$1,700,000

Federal Funding	State Funding	County Funding
\$0	\$0	\$1,700,000

Project Description:

The 911 Center uses Pulsiam CAD/RMS to dispatch for all Police, Fire and EMS agencies in the County. This product that we use was adopted when the UCC was formed. The program that the UCC uses for CAD dispatch is called Hiterm. This product is no longer being supported and we are being forced to use what we believe is a far less user-friendly system. There are only 3 agencies left in the entire state using this software as other options have far more capabilities. We have started demos for other vendor products and see immediate benefits to making a change. There will be a costs-sharing conversation that will need to happen as the City and Towns pay for the UCC also, however the initial Capital budget will need to go through the County Process.

Justification:

Our current product is no longer being supported so a change is needed. The intent here is to adopt one standardized CAD/RMS for the entire County to use. New systems are far more user-friendly which will cut down the lengthy training process for new hire dispatchers, provide immediate officer safety information that our current system does not, and standardize the county for information sharing purposes.



Schenectady County 2025 Capital Budget Request

Request Year: 2026

Department: Aviation

Project Name: Mini-Split Replacement
for Tower Cab

Classification: Equipment

Type: New



Estimated Start: 5/1/2026

Estimated Completion: 6/30/2026

Estimated Cost: \$70,000

Federal Funding	State Funding	County Funding
\$0	\$0	\$70,000

Project Description:

The project involves the replacement the two existing mini-split air conditioning system for the airport tower cab. The work will require the removal of the existing air handlers and the compressor / condenser and replacing with new equipment.

Justification:

The existing equipment, now over 15 years old, has become unreliable and requires ongoing maintenance to keep it operational. The tower cab, with 6-foot-tall windows around its entire perimeter, experiences significant temperature increases during the summer. Despite insulation and window upgrades since its construction in the 1950s, the heat gain remains substantial. Air conditioning units are essential to maintain a comfortable environment and ensure the proper functioning of electronic equipment.



Schenectady County 2025 Capital Budget Request

Request Year: 2026

Department: Glendale Nursing Home

Project Name: Nurse Call Bell System
Phase 3

Classification: Equipment

Type: Replacement/Renewal



Estimated Start: 1/1/2026 **Estimated Completion:** 12/31/2026

Estimated Cost: \$50,750

Federal Funding	State Funding	County Funding
\$0	\$0	\$50,750

Project Description:

Replacement of the Nurse Call Bell System for one unit

Justification:

To replace aging Nurse Call System. The parts for our current system have been discontinued. This will be a phased project to replace one unit per year.



Schenectady County 2025 Capital Budget Request

Request Year: 2026

Department: Schenectady County
Community College

Project Name: Classroom Furniture
Replacement

Classification: Equipment

Type: Replacement/Renewal



Estimated Start: 4/1/2026 **Estimated Completion:** 12/31/2026

Estimated Cost: \$250,000

Federal Funding	State Funding	County Funding
\$0	\$125,000	\$125,000

Project Description:
Replacement of classroom furniture

Justification:
Replacement of worn and used classroom furniture needed by students to attend class.



Schenectady County 2025 Capital Budget Request

Request Year: 2026

Department: Schenectady County
Community College

Project Name: Classroom Furniture
Replacement

Classification: Equipment

Type: Replacement/Renewal

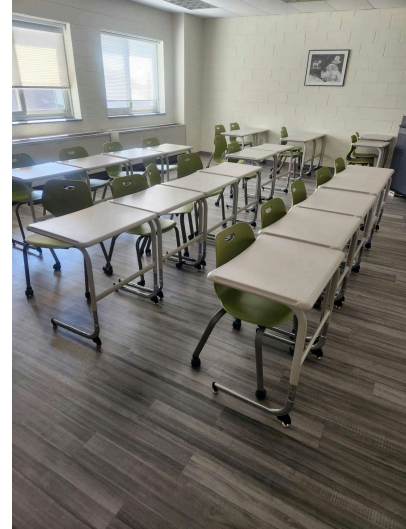

Estimated Start: 4/1/2026 **Estimated Completion:** 6/30/2026

Estimated Cost: \$500,000

Federal Funding	State Funding	County Funding
\$0	\$250,000	\$250,000

Project Description:

Replacement of outdated and non-ADA compliant classroom furniture.

Justification:

Main campus classroom furniture requires replacement due to wear and age. Current furniture is dated and, in some instances, not ADA compliant.



Schenectady County 2025 Capital Budget Request

Request Year: 2026

Department: Sheriff - All Divisions

Project Name: Sheriff Dept.: Vehicle Replacements and Upfitting

Classification: Equipment

Type: New



Estimated Start: 1/1/2026 **Estimated Completion:** 12/31/2026

Estimated Cost: \$250,000

Federal Funding	State Funding	County Funding
\$0	\$0	\$250,000

Project Description:

The Department of Engineering and Public Works manages the Sheriff's Department's fleet and recommends when replacement of vehicles is necessary. For 2026, the Sheriff's request is for:
 -Three (3) Patrol Interceptors with upfitting. Upfitting will include Panasonic Toughbook laptops and docking stations.

Justification:

Ongoing replacement of the Sheriff Patrol vehicles is necessary due to the annual mileage and associated wear and tear on the vehicles.



Schenectady County 2025 Capital Budget Request

Request Year: 2027

Department: Schenectady County
Community College

Project Name: Elston Hall: Facade Phase
5

Classification: Project

Type: New



Estimated Start: 1/1/2026 **Estimated Completion:** 12/31/2026

Estimated Cost: \$1,000,000

Federal Funding	State Funding	County Funding
\$0	\$500,000	\$500,000

Project Description:

Continuous restoration of the Elston Hall Facade and other exterior work.

Justification:

Bricks, windows, cast stone, and other replacements needed due to disrepair.



Schenectady County

2025 Capital Budget Request

Request Year: 2027

Department: Glendale Nursing Home

Project Name: Nurse Call Bell System
Phase 4

Classification: Equipment

Type: Replacement/Renewal



Estimated Start: 1/1/2027

Estimated Completion: 12/31/2027

Estimated Cost: \$50,750

Federal Funding	State Funding	County Funding
\$0	\$0	\$50,750

Project Description:

Replacement of the Nurse Call Bell System for one unit

Justification:

To replace aging Nurse Call System. The parts for our current system have been discontinued. This will be a phased project to replace one unit per year.



Schenectady County 2025 Capital Budget Request

Request Year: 2027

Department: Schenectady County
Compost & Recycling
Facility

Project Name: Compost Facility Front
End Loader

Classification: Equipment

Type: Replacement/Renewal



Estimated Start: 1/1/2027

Estimated Completion: 12/31/2027

Estimated Cost: \$343,000

Federal Funding	State Funding	County Funding
\$0	\$171,500	\$171,500

Project Description:

The Schenectady County Compost Facility accepted more than 20,000 cubic yards of yard-waste annually. This material needs to be processed into compost and wood mulch before being sold to the public. In order to move and process this material, the Front End Loaders are needed.

Justification:

The Hyundai Front End Loader, that will be replaced with new loader, was purchased in 2013. It has been in use since and now has 12,100 hours on the engine and drivetrain. This machine is crucial to the success of the Compost Facility and although it is running strong today, replacement will be necessary in a few years.



Schenectady County 2025 Capital Budget Request

Request Year: 2027

Department: Sheriff - All Divisions

Project Name: Sheriff Dept.: Vehicle Replacements and Upfitting

Classification: Equipment

Type: New



Estimated Start: 1/1/2027 **Estimated Completion:** 12/31/2027

Estimated Cost: \$250,000

Federal Funding	State Funding	County Funding
\$0	\$0	\$250,000

Project Description:

The Department of Engineering and Public Works manages the Sheriff's Department's fleet and recommends when replacement of vehicles is necessary. For 2027, the Sheriff's request is for:
 -Three (3) Patrol Interceptors with upfitting. Upfitting will include Panasonic Toughbook laptops and docking stations.

Justification:

Ongoing replacement of the Sheriff Patrol vehicles is necessary due to the annual mileage and associated wear and tear on the vehicles.



Schenectady County 2025 Capital Budget Request

Request Year: 2028

Department: Facilities

Project Name: Library: KBJ Library
Multistack Chiller Controls

Classification: Project

Type: New



Estimated Start: 1/1/2028 **Estimated Completion:** 12/31/2028

Estimated Cost: \$100,000

Federal Funding	State Funding	County Funding
\$0	\$0	\$100,000

Project Description:

Replace multi-stack chiller controls and pot feeder at Karen B. Johnson Library.

Justification:

The current control system is at the end of its useful life and we cannot easily get parts. As KBJ is a cooling station during the summer, we cannot afford for this to go down. We need to replace this and a pot feeder at the KBJ.



Schenectady County 2025 Capital Budget Request

Request Year: 2028

Department: Glendale Nursing Home

Project Name: Nurse Call Bell System
Phase 5

Classification: Equipment

Type: Replacement/Renewal



Estimated Start: 1/1/2028 **Estimated Completion:** 12/31/2028

Estimated Cost: \$50,750

Federal Funding	State Funding	County Funding
\$0	\$0	\$50,750

Project Description:

Replacement of the Nurse Call Bell System for one unit.

Justification:

To replace aging Nurse Call System. The parts for our current system have been discontinued. This will be a phased project to replace one unit per year.



Schenectady County 2025 Capital Budget Request

Request Year: 2028

Department: Sheriff - All Divisions

Project Name: Sheriff Dept.: Vehicle Replacements and Upfitting

Classification: Equipment

Type: New



Estimated Start: 1/1/2028 **Estimated Completion:** 12/31/2028

Estimated Cost: \$250,000

Federal Funding	State Funding	County Funding
\$0	\$0	\$250,000

Project Description:

The Department of Engineering and Public Works manages the Sheriff's Department's fleet and recommends when replacement of vehicles is necessary. For 2028, the Sheriff's request is for:
 -Three (3) Patrol Interceptors with upfitting. Upfitting will include Panasonic Toughbook laptops and docking stations.

Justification:

Ongoing replacement of the Sheriff Patrol vehicles is necessary due to the annual mileage and associated wear and tear on the vehicles.



Schenectady County 2025 Capital Budget Request

Request Year: 2029

Department: Engineering and Public Works

Project Name: Emergency Management Office: 2025 Mobile Command Post Vehicle

Classification: Equipment

Type: Replacement/Renewal



Estimated Start: 1/1/2028 **Estimated Completion:** 12/31/2028

Estimated Cost: \$1,500,000

Federal Funding	State Funding	County Funding
\$0	\$0	\$1,500,000

Project Description:

New 2025 Mobile Command Post Vehicle for Emergency Management Department

Justification:

This unit will replace 3311, a mobile command post C-100 which is a 2003 Miranda mobile home that has been semi converted to a command post configuration. It is in very poor condition with numerous issues. This vehicle is used to support major functions throughout the County along with UCC emergencies.



Schenectady County

2025 Capital Budget Request

Request Year: 2029

Department: Sheriff - All Divisions

Project Name: Sheriff Dept.: Vehicle Replacements and Upfitting

Classification: Equipment

Type: New



Estimated Start: 1/1/2029

Estimated Completion: 12/31/2029

Estimated Cost: \$250,000

Federal Funding	State Funding	County Funding
\$0	\$0	\$250,000

Project Description:

The Department of Engineering and Public Works manages the Sheriff's Department's fleet and recommends when replacement of vehicles is necessary. For 2029, the Sheriff's request is for:

- Three (3) Patrol Interceptors with upfitting. Upfitting will include Panasonic Toughbook laptops and docking stations.

Justification:

Ongoing replacement of the Sheriff Patrol vehicles is necessary due to the annual mileage and associated wear and tear on the vehicles.

